

EQUIPMENT SPECS

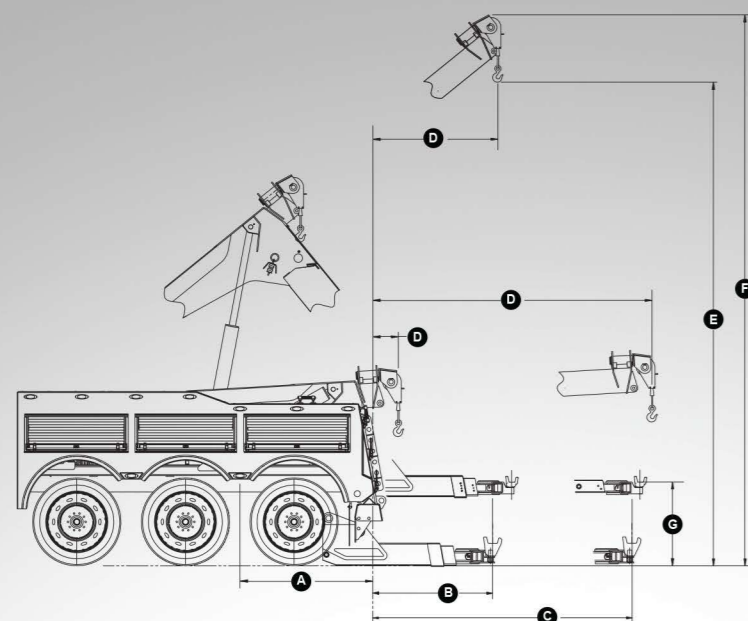

Note: All values are based on a 42" truck frame height and are rounded to the nearest inch. Values are subject to change without notice.

RECOVERY BOOM	RATING
Boom Retracted at 30°	70,000 lbs.
Boom Extended at 30°	22,000 lbs.

FEATURE DIMENSIONS	REACH	RATING
A Centerline of Rear Tandem to Tailboard	66"	—
B 300 Coach U/L Retracted Reach w/Forks	68"	30,000 lbs.
350 U/L Retracted Reach w/Forks	62"	35,000 lbs.
C 300 Coach U/L Extended Reach w/Forks	146"	16,000 lbs.
350 U/L Extended Reach w/Forks	128"	16,000 lbs.
Recovery Boom Retracted Reach at 0°	14"	—
Recovery Boom Retracted Reach at 30°	-15"	70,000 lbs.
D Recovery Boom Retracted Reach at 40° (Max)	-32"	—
Recovery Boom Extended Reach at 0°	134"	—
Recovery Boom Extended Reach at 30°	89"	22,000 lbs.
Recovery Boom Extended Reach at 40° (Max)	61"	—
E Boom Working Height to Hook at 30°	197"	—
Boom Working Height to Hook at 40° (Max)	233"	—
F Boom Max Height at 40° (Max)	264"	—
G 300 Coach U/L Max Towing Height	42"	—
350 U/L Max Towing Height	43"	—

The 35 ton—like all Jerr-Dan underlifts—has full cycle power tilt. This feature allows the operator to have tilt capabilities in positive or negative grade lift positions. The positive and negative tilt allows you to pick vehicles up on uneven terrain, while maintaining clearance between the undercarriage and underlift.

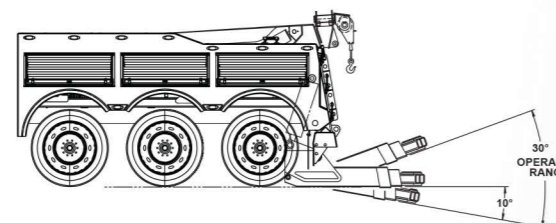

RECOMMENDED CHASSIS REQUIREMENTS

35 TON INTEGRATED	TANDEM	TRI-AXLE
Min Chassis GVWR	54,000 lbs.	54,000 lbs.
Min Cab to Drive Tandem (Clear CT)	154"	154"
Min Frame RBM (each rail)*	3,250,000 in-lbs.	3,250,000 in-lbs.
Min FAWR*	14,600 lbs.	14,600 lbs.
Min RAWR	40,000 lbs.	40,000 lbs.
Max Unloaded Frame Height	45"	45"
Min Frame Length Behind Rearmost Axle	43"	43"

*Higher minimums are required if mounting in combination with a Side Recovery System (SRS). Refer to SRS sales literature for requirements.

SHEET SPEC

STANDARD FEATURES

- 2-Section High-Strength Hydraulic Boom
- Max Lifting Capacity:

Boom Angle	Retracted	Extended
30°	70,000 lbs.	22,000 lbs.
- Max Boom Extension: 134" (11' 2")
- Max Working Height: 233" (19' 5") (Ground to Hook)
- Wrecker Boom Winches
 - Dual Planetary 35,000 lbs. Capacity
 - 5/8 in. x 200 ft. or 250 ft. Wire Rope w/ 360° Swivel Hooks
 - Air Cable Tensioners & Free Spool
- High-Performance Polymer Slide Pads
- Boom Mounted D-Rings
- Driver & Passenger Side Proportional Controls
- Driver & Passenger Side Hyd. Pressure Gauges
- 3-Location Multiplex Electrical Controls
- 2-Location Multiplex Air Controls
- Telescoping Rear Stabilizers w/Integrated Fold-Down Spade Feet
- Recessed Glad Hand & 7-Pin Connectors
- LED Amber Main & Auxiliary Light Bars
- LED Upper & Lower Hook-Up Lights
- LED Upper Work Lights
- LED Underlift Lights
- Jerr-Dan Boom/Body Logos
- Custom JFB Signature Badge

OPTIONAL:

- 3/4 in. x 200 ft. Wire Rope w/ 360° Swivel Hooks
- Wireless Proportional Remote Control or Non-Proportional (All Boom Functions)
- 6 Side & 2 Rear Emergency Flashers (CA Compliant)
- 39" & 51" Tunnel Compartments
- Aluminum Dress Up Kit

See your Jerr-Dan dealer for more options and accessories.

ACCESSORIES

- Counterweight Options:
 - Front Casted Counterweight/Tunnel Counterweight
 - Ranging from 1500–3500 lbs./3000–6500 lbs.
- Available SRS 25 & SRS 35
- Rigging Kits Available
- Storage Solution Kits
- Back-Up Camera

UNDERLIFT FEATURES

- Retracted Lift Capacity & Reach (Off Tailboard):

Model	Capacity	Reach
300	30,000 lbs.	68 in.
350	35,000 lbs.	62 in.

- Extended Lift Capacity & Reach (Off Tailboard):

Model	Capacity	Reach
300	16,000 lbs.	146 in.
350	16,000 lbs.	128 in.

- Max Towing Height & Negative Power Tilt:

Model	Tow Height	Neg. Tilt
300	42 in.	10°
350	43 in.	10°

- 3-Section High-Strength Hydraulic Boom
- 14,000 lbs. or 25,000 lbs. Tire Lift Option
- HD Tie-Down Straps, Chain Hook Adapters, Forks & Spring Lift Brackets Included
- 70° Side Pivoting Low Profile Cross Bar w/ 5" Pin
- Underlift Camera (Option)

YOUR JERR-DAN DEALER:

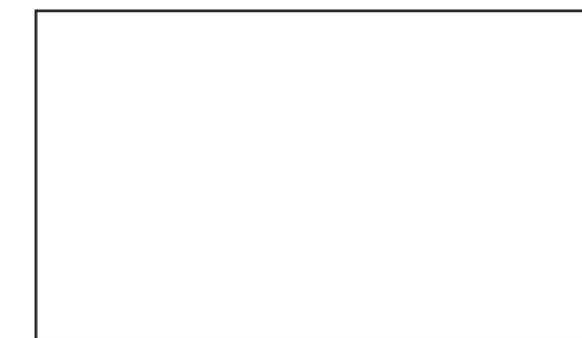

THE 35 TON INTEGRATED WRECKER



Eastern Wrecker Sales, Inc
www.easternwrecker.com - 919-553-4038

An Oshkosh Corporation Company. The Jerr-Dan name and Jerr-Dan logo are registered trademarks of Oshkosh Corporation, ©2015 Jerr-Dan Corporation.

An Oshkosh Corporation Company. The Jerr-Dan name and Jerr-Dan logo are registered trademarks of Oshkosh Corporation, ©2015 Jerr-Dan Corporation.

JFB BODY SERIES

ROLL UP READY FOR ANYTHING

The JFB Body Series delivers what matters most: performance, innovation and dependability.

- Increased storage capacity
- Storage for towing equipment & rigging organization
- Incident management-oriented design
- Aluminum roll-up doors for improved compartment access & operator visibility
- Access & egress that meets the highest standard in body construction
- Rotator-style control stations
- LED interior compartment & DOT lighting for enhanced nighttime operations
- Limited Lifetime Warranty*—transferable for greater return on investment
- Sectional rubber-mounted body for greater shock-absorbing performance
- Diamond tread and anti-skid surfaces for service access to top of body
- LED-lighted steps & grab handles for nighttime tailboard access
- Load-rated access & tool storage areas

The JFB body series is available in a gold or silver series. Gold offers pre-set storage solutions (for a “turn-key” unit), and the silver series allows the operator to organize the interior.

SRS (Side Recovery System) option with pivoting recovery boom allows for recovery ability on either side of the unit. Mounted behind the cab, the SRS (with 37” tool compartments) puts functional weight toward the front of the unit for increased towing performance.



*48 business hours from notification, valid in North America only, some restrictions apply. Limited lifetime warranty provided only by the body supplier and not Jerr-Dan. For more information or to obtain a copy of the limited lifetime warranty, contact Jerr-Dan warranty department.

An Oshkosh Corporation Company. The Jerr-Dan name and Jerr-Dan logo are registered trademarks of Oshkosh Corporation, ©2015 Jerr-Dan Corporation.



ENGINEERED FOR INCIDENT MANAGEMENT

THE JFB BODY SERIES WORKS HARDER AND LASTS LONGER

Meet the strongest body on the market—the JFB. Its rugged, non-corrosive exterior, made of weather-tight and impact-resistant polypropylene, is so durable it comes with a limited Lifetime Warranty on the body. And, its roll-up aluminum doors, strategically placed LED lights and engineered storage solutions prove it has more than just brawn—it’s got the brains too.

*The JFB body is available for tandem and tri-axle chassis.



POLY TIRE LIFT ORGANIZER



ADJUSTABLE SHELVING

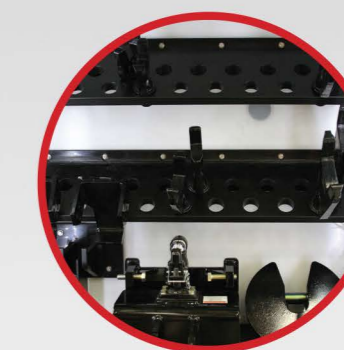

LIFT ATTACHMENT STORAGE (18 SETS OF FORKS)
NON-CORROSIVE POLY CONSTRUCTION



CHAIN CAROUSEL OIL DRY SILO

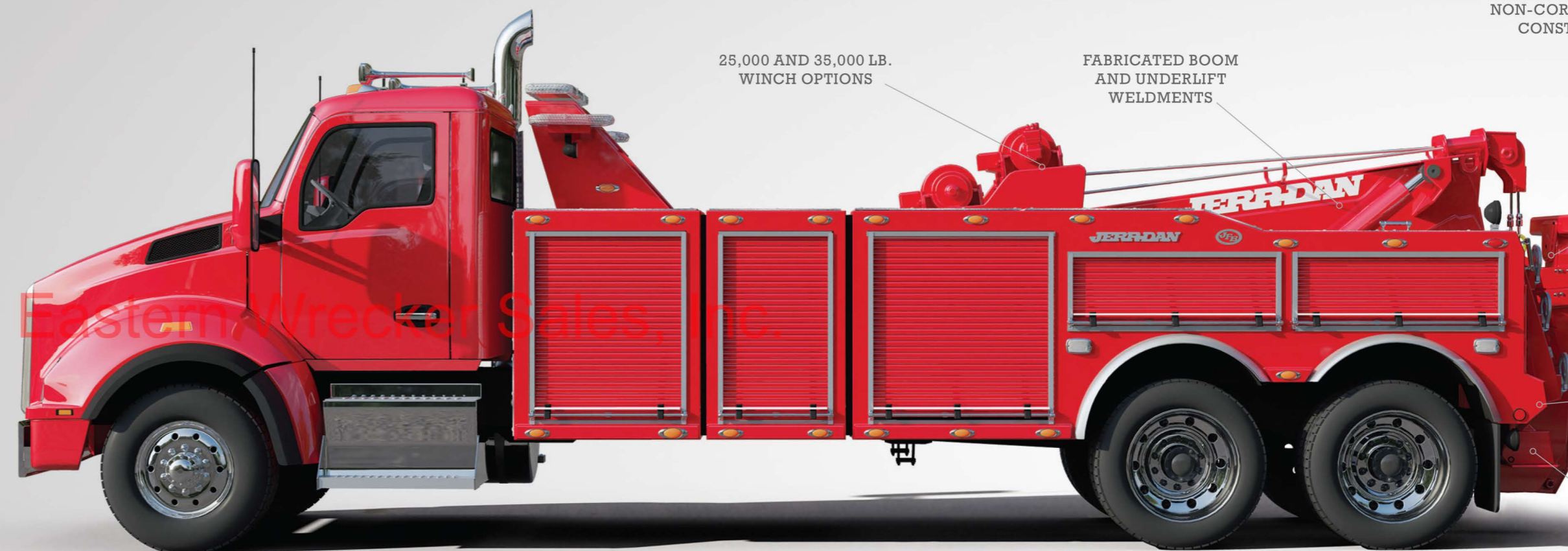

25,000 AND 35,000 LB. WINCH OPTIONS

FABRICATED BOOM AND UNDERLIFT WELDMENTS

5-INCH STEEL CENTER PIN AND STEEL BUSHING

AUTOMOTIVE WIRING HARNESSES AND CONNECTIONS

WIDENED SPADE FOOT

Jerr-Dan 35 Ton Integrated JFB Wrecker



ROTATOR-STYLE CONTROL STATIONS

LED COMPARTMENT LIGHTING



RECOVERY RIGGING STORAGE



TILT DOWN TRAYS



POWER DISTRIBUTION CENTER



LED WORK LIGHTING

LOAD RATED HANDLES / STEPS W/ ANTI-SLIP TEXTURING



MULTI-PLEX LIGHTING

WINCH FREE-SPOOL CONTROLS

THE WRECKER THAT GOES THE EXTRA MILE

With innovative tool storage and unmatched performance, the 35 Ton Integrated Wrecker is “best-in-class” in towing and recovery. Fabricated boom and underlift equipment provide the high strength demanded by today’s heavy duty tasks. The 5-inch steel crossbar center pin coupled with the steel bushing are unparalleled in service life. Interchangeable tool compartments and optimized rigging management provide for an extremely efficient and entirely customizable interior. Why? So you can organize it your way.