

MEDIUM-DUTY WRECKERS

MDL 280/110 14-Ton and MDL 320/110 16-Ton Integrated and Independent Wreckers



MEDIUM-DUTY WRECKERS WITH HEAVY-DUTY ATTITUDES

MDL 280/110 14-Ton and MDL 320/110 16-Ton Integrated and Independent Wreckers

Experience the best characteristics of the heavy-duty line in compact packages with these swift and easy-to-use trucks. Also extremely versatile—tow cars, pickups, light and medium-duty trucks—they offer the only medium-duty tire lifts in their class.

Each medium-duty wrecker from Jerr-Dan features dual 15,000 lb planetary winches, a fold-up underlift and a double-door crossover tool compartment for easier storage. Plus, the optional rotating recovery spade gives this rig added stability, even for tough side pulls.

Recommended Chassis Requirements Integrated and Independent

• Minimum GVWR	30,000 lbs
• Minimum Cab to Axle (clear)	108"
• Minimum Frame RBM (each rail)	850,000 in-lbs
• Minimum Front GAWR	10,000 lbs
• Minimum Rear GAWR	20,000 lbs
• Maximum Unloaded Frame Height	41"
• Minimum Frame Length Behind Rear Axle	37"

FEATURES



Rotating Recovery Spade
Anchoring the wrecker for side pull recoveries at various angles.



7,500 lb Rated Tire Lift
Ideal for motorhomes and tractor swap.



Standard Dual Controls
Provide the option to operate from either driver or passenger side of the wrecker.



Low Profile Wheel Grids
Allows for towing of cars with low ground clearance.



Standard Light Pylon
Aerodynamic light pylon is standard equipment on medium and heavy-duty wreckers.

SPECIFICATIONS

INTEGRATED	Distance	Rating
A. Centerline of Rear Axle to Rear of Tailboard	39"	
B. Reach with Forks, retracted (rear of tailboard to centerline of forks)	48"	11,000 lbs
C. Reach with Forks, extended (rear of tailboard to centerline of forks)	78"	8,500 lbs
D. Reach with L-Arms, retracted (rear of tailboard to centerline of L-Arms)	55"	5,000 lbs
E. Reach with L-Arms, extended (rear of tailboard to centerline of L-Arms)	85"	5,000 lbs
F. Reach with Optional Tire Lift, retracted (rear of tailboard to centerline of optional tire lift)	45"	7,500 lbs
G. Reach with Optional Tire Lift, extended (rear of tailboard to centerline of optional tire lift)	75"	7,500 lbs
H. Boom Reach Off Rear of Tailboard (boom @ 0°)	72"	
I. Boom Working Height to Hook (boom @ 45°)	175"	
J. Boom Maximum Height (boom @ 45°)	201"	

INDEPENDENT	Distance	Rating
A. Centerline of Rear Axle to Rear of Tailboard	39"	
B. Reach with Forks, retracted (rear of tailboard to centerline of forks)	45"	11,000 lbs
C. Reach with Forks, extended (rear of tailboard to centerline of forks)	75"	8,500 lbs
D. Reach with L-Arms, retracted (rear of tailboard to centerline of L-arms)	52"	5,000 lbs
E. Reach with L-Arms, extended (rear of tailboard to centerline of L-arms)	82"	5,000 lbs
F. Reach with Optional Tire Lift, retracted (rear of tailboard to centerline of optional tire lift)	42"	7,500 lbs
G. Reach with Optional Tire Lift, extended (rear of tailboard to centerline of optional tire lift)	72"	7,500 lbs
H. Maximum Horizontal Towing Height with Forks	32"	
I. Maximum Horizontal Towing Height with L-Arms and Optional Tire Lift	22"	
J. Boom Reach Off Rear of Tailboard (boom @ 0°)	72"	
K. Boom Working Height to Hook (boom @ 45°)	175"	
L. Boom Maximum Height (boom @ 45°)	201"	

INTEGRATED and INDEPENDENT BOOM LIFT RATINGS (SAE J2512)	Rating
14-Ton Boom	
Boom Retracted @ 30°	28,000 lbs
Boom Extended @ 30°	14,000 lbs
16-Ton Boom	
Boom Retracted @ 30°	32,000 lbs
Boom Extended @ 30°	14,000 lbs

Note: All values are based on a 41" truck frame height and are rounded to the nearest inch.

Values subject to change without notice.

INTEGRATED

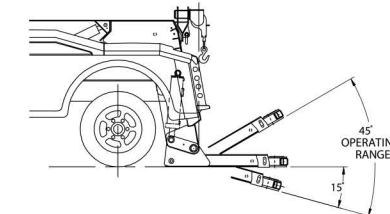
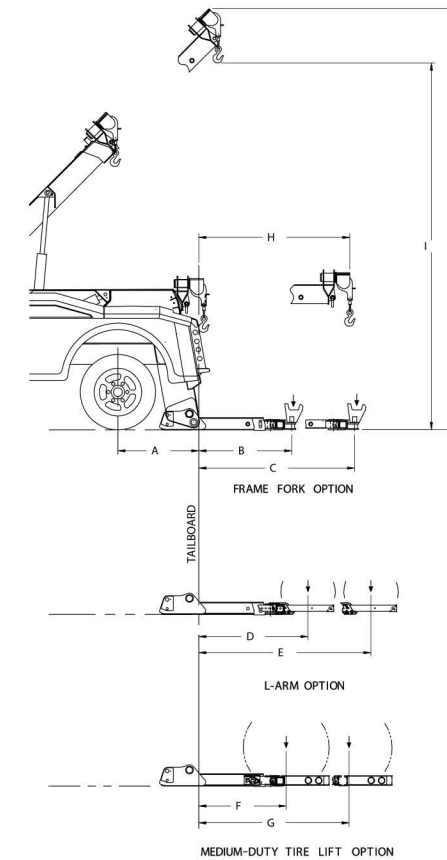

INDEPENDENT

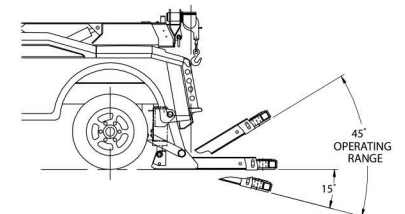
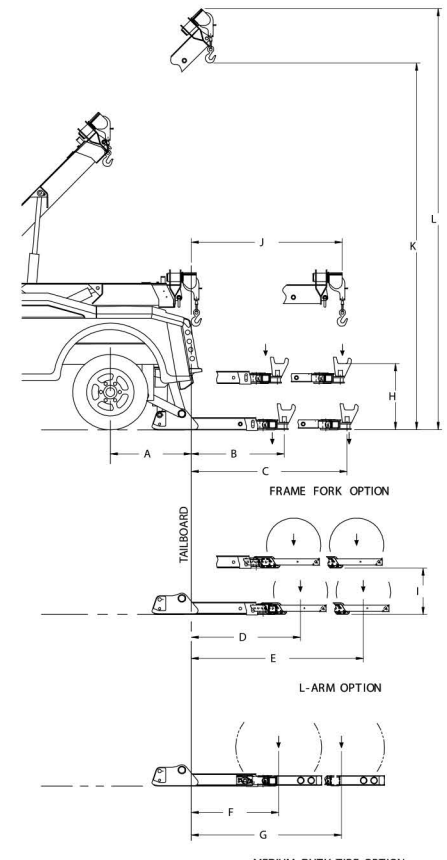

Eastern Wrecker Sales, Inc
www.easternwrecker.com - 919-553-4038