

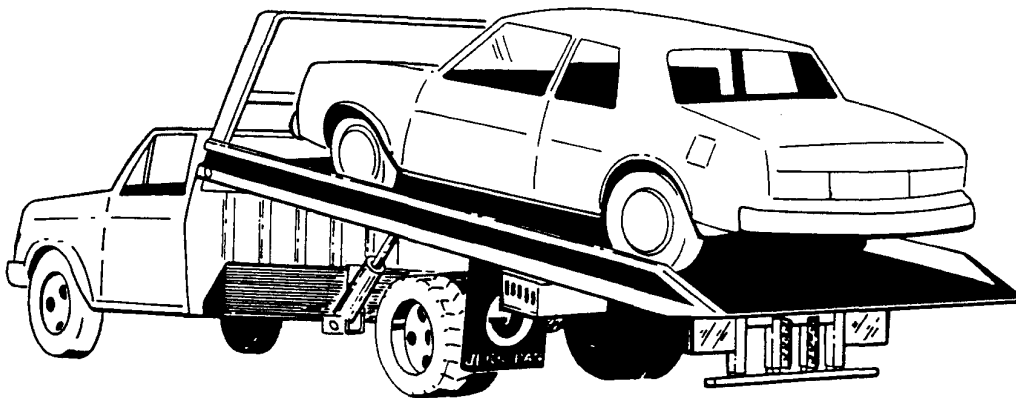

# RUSTLER

## OPERATION, MAINTENANCE, AND PARTS MANUAL



**JERR-DAN**  
**CORP.**

1080 Hykes Road

Greencastle, PA 17225

Phone (717) 597-7111

951106

**PARTS LIST — DECK**

<b>Ref. No.</b>	<b>Part No.</b>	<b>Description</b>	<b>Qty.</b>
1	D3-097-000036	Steel Deck (17')	1
	D3-097-000035	Steel Deck (18')	
	D3-097-000047*	Steel Deck (19')	
	D3-097-000034	Aluminum Deck (17')	
	D3-097-000032	Aluminum Deck (18')	
	D3-097-000048*	Aluminum Deck (19')	
2	C3-241-000021	Head Board (Low)	1
	C3-241-000022	Head Board (High)	
3	7-108-201450	Hex Head Capscrew	4
4	7-950-200152	Flat Washer	4
5	7-660-200035	Hex Nut	2
6	D7-970-000008	Winch Assembly	1
7	7-950-160050	Lock Washer	8
8	7-115-160850	Hex Head Capscrew	8
9	7-115-181450	Hex Head Capscrew	4
10	7-660-182301	Flanged Lock Nut	4
11	7-626-000008	Orbit Motor	1
12	7-950-180450	Lock Washer	2
13	7-111-181050	Hex Head Capscrew	2
14	A7-248-000001	Cable	1
15	7-590-000010	Amber Light	2
16	C4-706-000988	Striker Plate	1
17	7-115-161050	Hex Head Capscrew (Aluminum Decks Only)	2
18	7-660-162301	Flanged Lock Nut (Aluminum Decks Only)	2
19	A4-706-000989	Plate (Aluminum Decks Only)	2

Rev. 1

Date 5-1-92

DECK

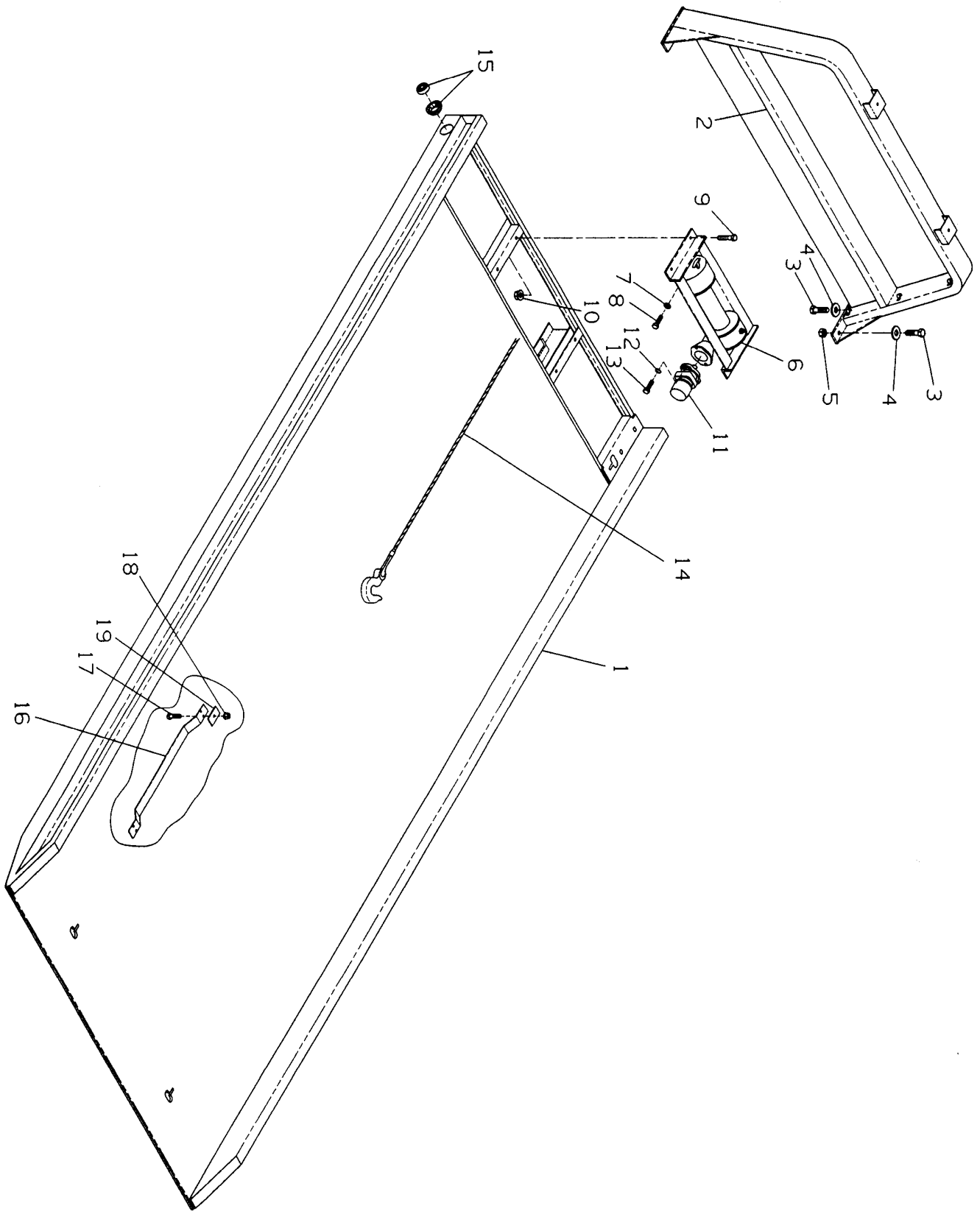

FINAL ASSEMBLY BASIC UNIT

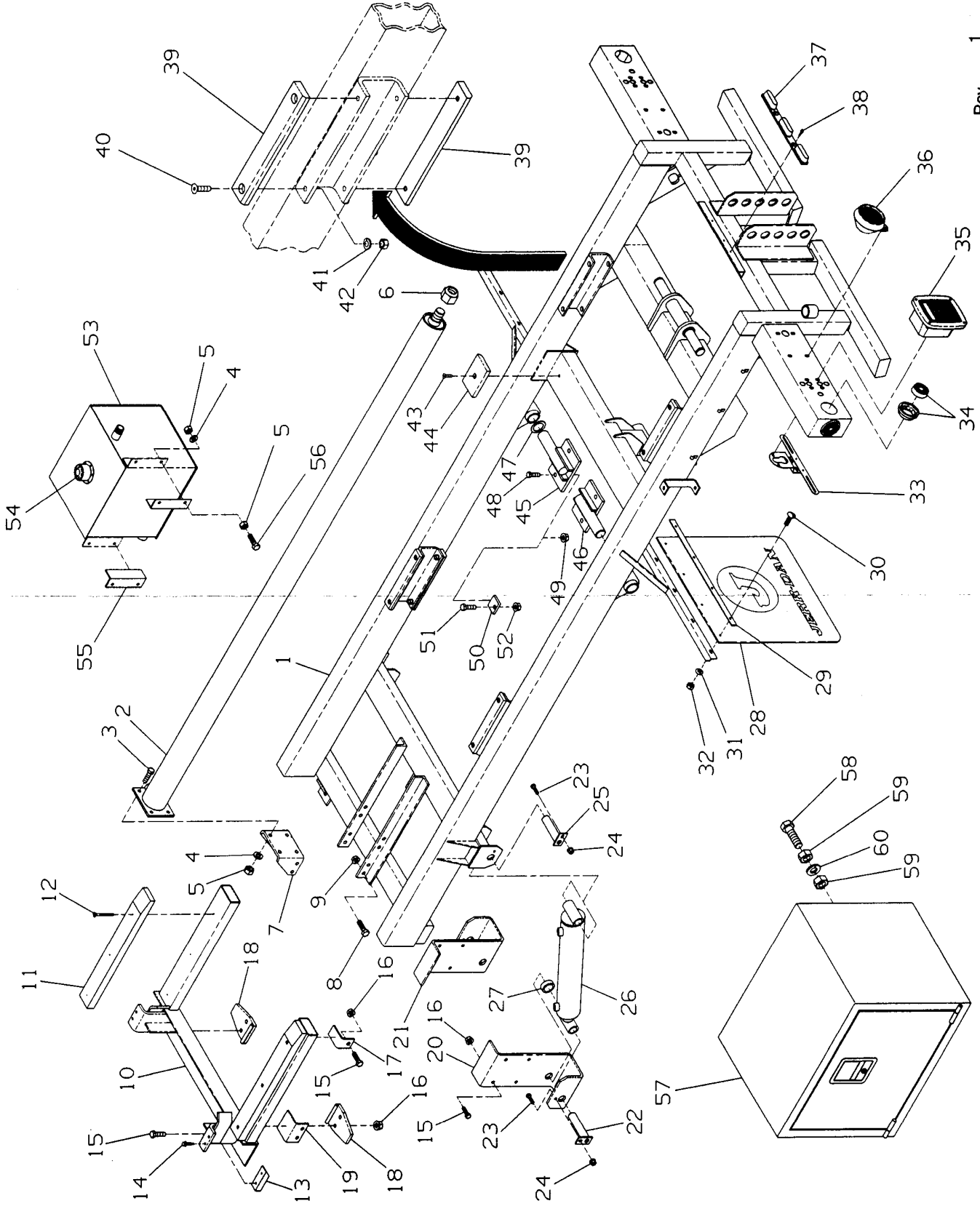

Rev. 1  
Date 5 / 2

## PARTS LIST — FINAL ASSEMBLY BASIC UNIT

Ref. No.	Part No.	Description	Qty.
1	D3-868-000039	Subframe	1
2	C3-320-000010	Rollback Cylinder	1
3	7-115-181450	Hex Head Capscrew	4
4	7-950-180000	Lock Washer	8
5	7-660-180000	Hex Nut	8
6	7-660-262031	Lock Nut	1
7	C4-178-000154	Bracket	1
8	7-115-181250	Hex Head Capscrew	4
9	7-661-000011	Flanged Lock Nut	4
10	C3-636-000038	Hold Down Base	1
11	4-679-000079	Wood Block	2
12	7-120-000010	Self-drilling Screw	6
13	A4-679-000020	Hold Down Pad	2
14	7-790-151656	Self-tapping Screw	4
15	7-105-181450	Hex Head Capscrew	14
16	7-660-182333	Flanged Lock Nut	14
17	B4-017-000405*	Retaining Angle	2
18	A3-274-000004*	Retaining Clamp (Fords & Internationals)	2
19	B4-017-000457*	Retaining Clamp (Chevys)	2
20	C4-178-000178*	L.H. Saddle	1
21	C4-178-000179*	R.H. Saddle	1
22	3-691-000092	Pin Weldment	2
23	7-115-160850	Hex Head Capscrew	4
24	7-660-162301	Flanged Lock Nut	4
25	3-691-000073	Pin Weldment	2
26	C3-320-000009	Tilt Cylinder	2
27	A4-209-000020	Spacer	2
28	C7-638-000004	Mud Flap	2
29	B4-706-000233	Back-up Strip	2
30	7-111-150813	Truss Head Screw	8
31	7-950-150000	Lock Washer	8
32	7-660-150000	Hex Nut	8
33	3-555-184002	Bracket	1
34	A7-590-000009	Clearance Light (Red)	4
35		Stop, Turn, Tail Lamp	2
36	A7-590-000011	Work Light	2
37	A7-590-000007	Bar Light	1
38	7-790-141056	Self-tapping Screw	2
39	A4-679-000016	Wear Pad	8
40	7-115-161023	Flat Head Capscrew	16
41	7-950-160000	Lock Washer	16
42	7-660-160000	Hex Nut	16
43	7-118-160623	Flat Head Capscrew	2
44	A4-679-000019	Wear Pad	2
45	B3-691-000082*	R.H. Trunnion Pin	1
	B3-691-000080	R.H. Trunnion Pin (Chevy 3500HD)	1
46	B3-691-000083*	L.H. Trunnion Pin	1
	B3-691-000080	L.H. Trunnion Pin (Chevy 3500HD)	1
47	A7-949-000003	Washer	2
48	7-105-201450	Hex Head Capscrew	4
49	7-660-202331	Flanged Lock Nut	4
50	A4-706-000964	Fill Plate (Chevy 3500HD)	2
51	7-105-201650	Hex Head Capscrew (Chevy 3500HD)	2
52	7-660-202331	Flanged Lock Nut (Chevy 3500HD)	2
53	C4-750-000002*	Oil Reservoir	1
54	7-183-000002	Filler Breather Cap	1
55	B4-017-000063	Angle	2
56	7-115-181850	Hex Head Capscrew	4
57	3-899-000009*	Tool Box	1
	3-899-000011	Tool Box with Stainless Steel Door	1
58	7-105-221050	Hex Head Capscrew	4
59	7-660-221338	Hex Nut	8
60	7-950-220000	Lock Washer	8

\* Consult Factory For Foreign Chassis Components

Rev. 1

4.4

Date 5-1-92

**PARTS LIST — DUAL CONTROLS  
(5 BANK VALVE SHOWN)**

Ref. No.	Part No.	Description	Qty.
1	D3-177-000027	Controls Support Weldment	1
2	4-935-000029	Control Valve (5 Bank)	1
	4-935-000028	Control Valve (4 Bank)	
	4-935-000027	Control Valve (3 Bank)	
3	7-111-162250	Hex Head Capscrew	3
4	7-660-161605	Hex Lock Nut	3
5	7-950-160151	Flat Washer	3
6	7-660-181600	Hex Lock Nut	4
7	7-950-180161	Flat Washer	4
8	C7-330-000096	Control Decal, L.H.	1
9	C7-330-000095	Control Decal, R.H.	1
10	A7-759-000004	Pop Rivet	8
11	7-632-040431	Moulding	2
12	A7-590-000012	Light	2
13	A4-763-000123	Control Rod	2, 3, 4
14	A4-763-000127	Control Rod	1
15	B3-763-000050	Control Rod	3, 4, 5
16	7-690-151200	Clevis Pin	12, 16, 20
17	7-690-021610	Cotter Pin	12, 16, 20
18	B4-017-000412	Angle	1
19	B4-706-000987	Plate	1
20	7-111-150850	Hex Head Capscrew	4
21	7-950-150161	Flat Washer	4
22	7-660-152600	Hex Lock Nut	4
23	A4-606-000065	Lug	4
24	A4-691-000141	Pin	2
25	C3-551-000012	Handle Weldment	2
26	C3-551-000001	Handle Weldment	2, 2, 2
27	C3-551-000017	Handle Weldment	2, 2, 2
28	C3-551-000002	Handle Weldment	0, 2, 2
29	C3-551-000013	Handle Weldment	0, 0, 2
30	A7-754-000009	Retaining Ring	4
31	7-111-150813	Truss Head Machine Screw	8
32	7-950-150000	Lock Washer	8
33	7-660-150000	Hex Nut	8
34	A7-551-000002	Knob, Black	4, 6, 8
35	A7-551-000003	Knob, Red	2
36	7-440-030000	Grease Fitting	6, 8, 10
37	A7-843-000011	Spring	1
38	7-754-000035	Retaining Ring	1
39	B4-064-000016	Plunger Bar	1
40	A4-206-000021	Bushing	2, 2, 0
41	7-950-170152	Flat Washer	1

Rev. \_\_\_\_\_

Date \_\_\_\_\_

TRUCK CAB

TRUCK CONTROLS

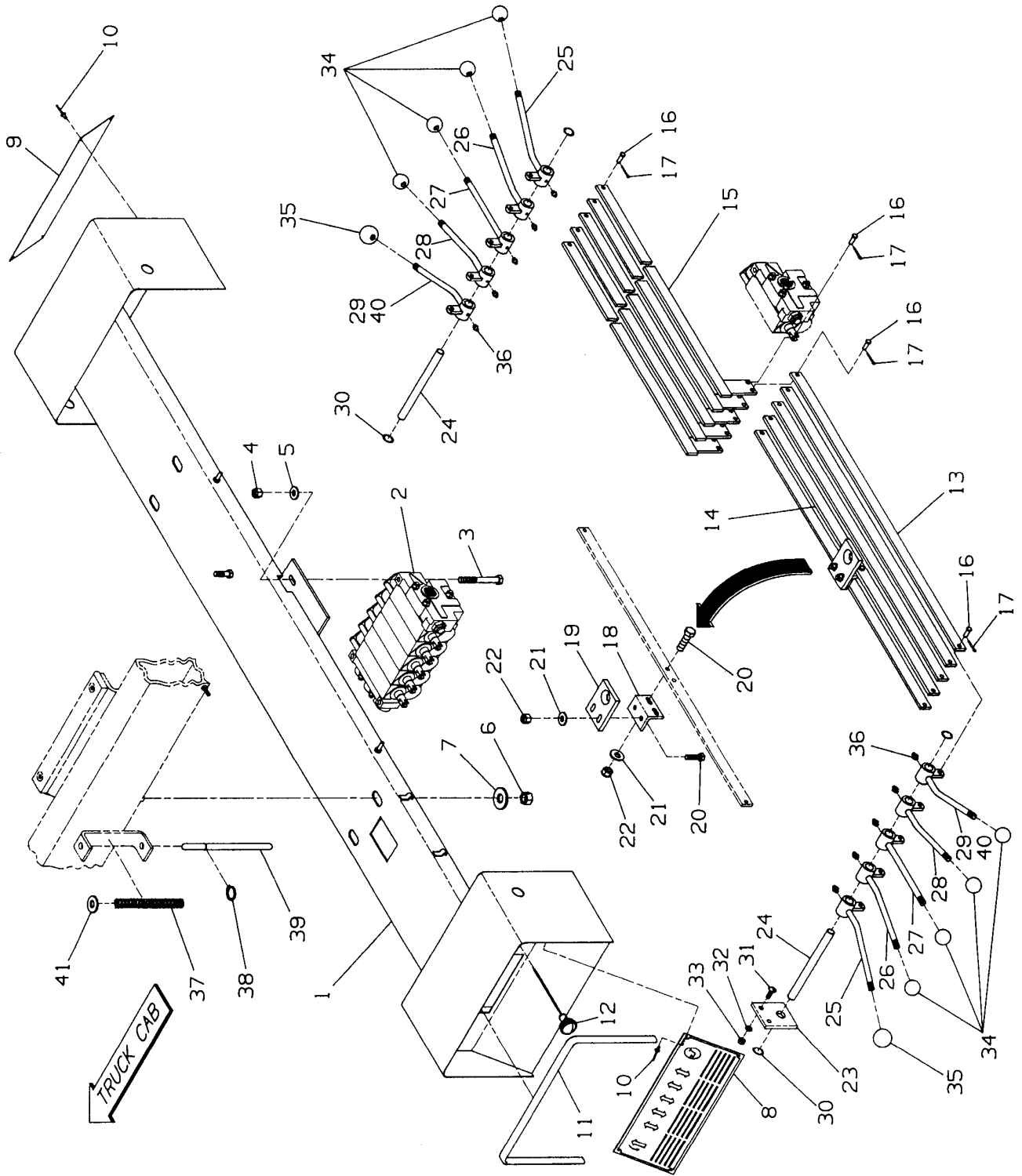

Rev. \_\_\_\_\_  
Date \_\_\_\_\_

1500# HYDRAULIC TOW BAR

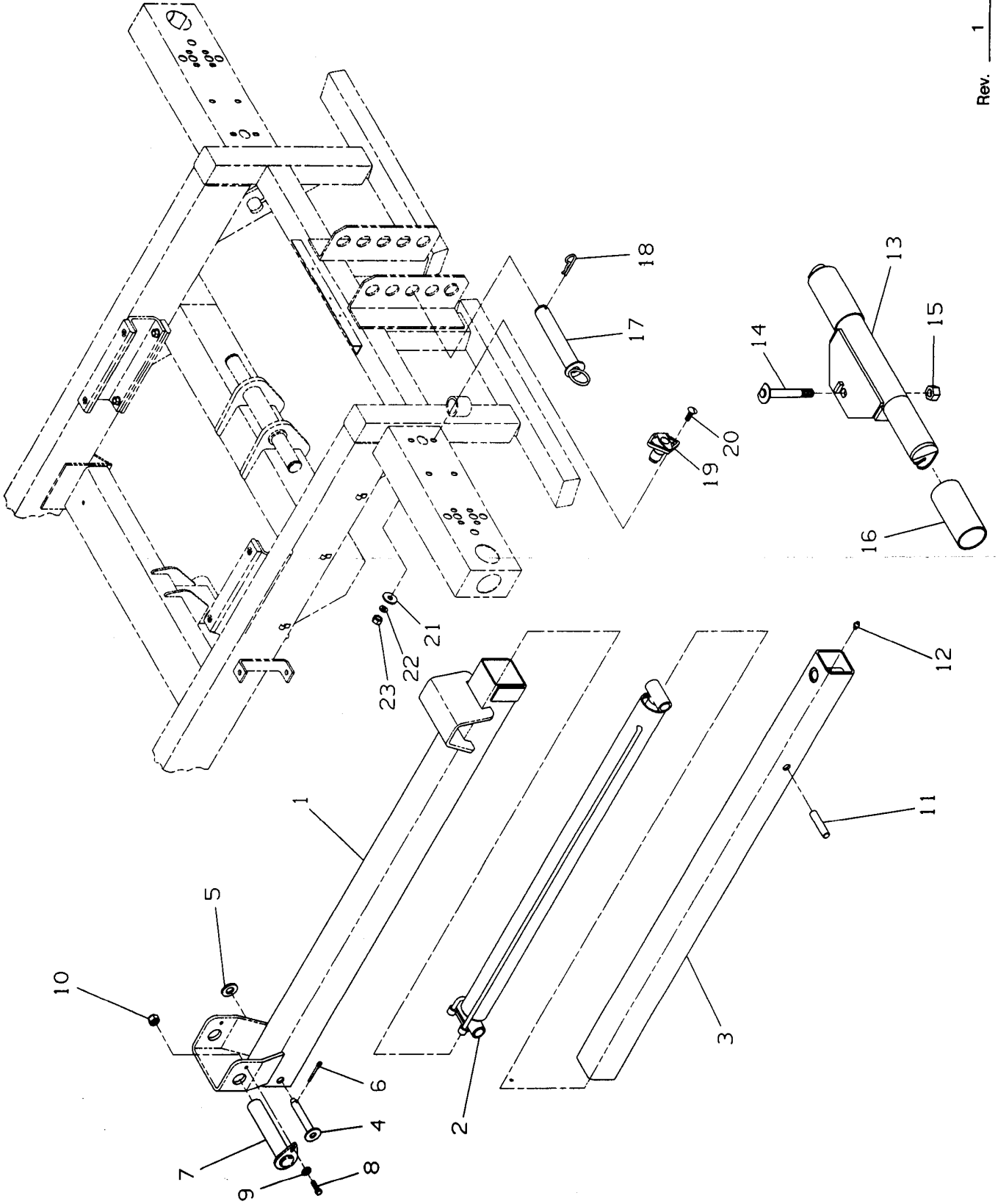

Rev. 1  
Date 5-1-9

4.7

5-375 074-REV-1



**PARTS LIST — 1500# HYDRAULIC TOW BAR INSTALLATION**

<b>Ref. No.</b>	<b>Part No.</b>	<b>Description</b>	<b>Qty.</b>
1	C3-170-000034	Outer Tube Weldment	1
2	C3-320-000013	Tow Bar Cylinder	1
3	B3-170-000035	Inner Tube Weldment	1
4	A3-691-000025	Pin Weldment	1
5	7-950-220161	Flat Washer	1
6	7-690-144010	Cotter Pin	1
7	3-691-000074	Pin Weldment	1
8	7-118-151250	Hex Head Capscrew	1
9	7-950-150161	Flat Washer	1
10	7-660-152600	Lock Nut	1
11	A4-691-000042	Pin	1
12	7-440-030000	Grease Fitting	1
13	C3-556-000006	Tow Hitch	1
14	A3-691-000026	Hitch Pin	1
15	7-660-261630	Lock Nut	1
16	A7-912-000011	Rubber Tube	2
17	A3-691-000097	Pin Weldment	1
18	A7-691-000001	Hair Pin	1
19	A7-291-000003	Female Receptacle	1
20	7-111-140613	Truss Head Screw	2
21	7-950-140161	Flat Washer	2
22	7-950-140000	Lock Washer	2
23	7-660-140000	Hex Nut	2

Rev. 1

Date 5-1-92

**PARTS LIST — 3500# HYDRAULIC TOW BAR  
WITH AND WITHOUT IRL**

Ref. No.	Part No.	Description	Qty.
1	D3-170-000047	Outer Tube Weldment	1
2	C3-320-000020	Tow Bar Cylinder	1
3	D3-170-000048	Inner Tube Weldment	1
4	A3-691-000042	Pin Weldment	1
5	A7-754-000006	Retaining Ring	2
6	A3-691-000011	Pin Weldment	1
7	3-691-000093	Pin Weldment	1
8	7-115-161250	Hex Head Capscrew	1
9	7-660-162301	Flanged Lock Nut	1
10	7-950-160161	Flat Washer	1
11	7-440-000200	Grease Fitting 45°	1
12	A3-691-000097	Pin Weldment	1
13	A7-691-000001	Hair Pin	1
14	A7-291-000003	Female Receptacle	1
15	7-111-140613	Truss Head Screw	2
16	7-950-140161	Flat Washer	2
17	7-950-140000	Lock Washer	2
18	7-660-140000	Hex Nut	2
19	A3-606-000014	Lug Weldment	1
20	C3-320-000041	IRL Cylinder	2
21	C3-178-000155	Bracket	1
22	A7-949-000008	Washer	4
23	7-754-000014	Retaining Ring	4
24	C3-556-000023	Tow Hitch	1
25	A7-912-000011	Rubber Tube	2
26	A4-120-000008	Bolt	1
27	A4-209-000020	Spacer	2

Rev. 1

Date 5-1-92

3500\* HYDRAULIC TOW BAR  
H AND WITHOUT IRL

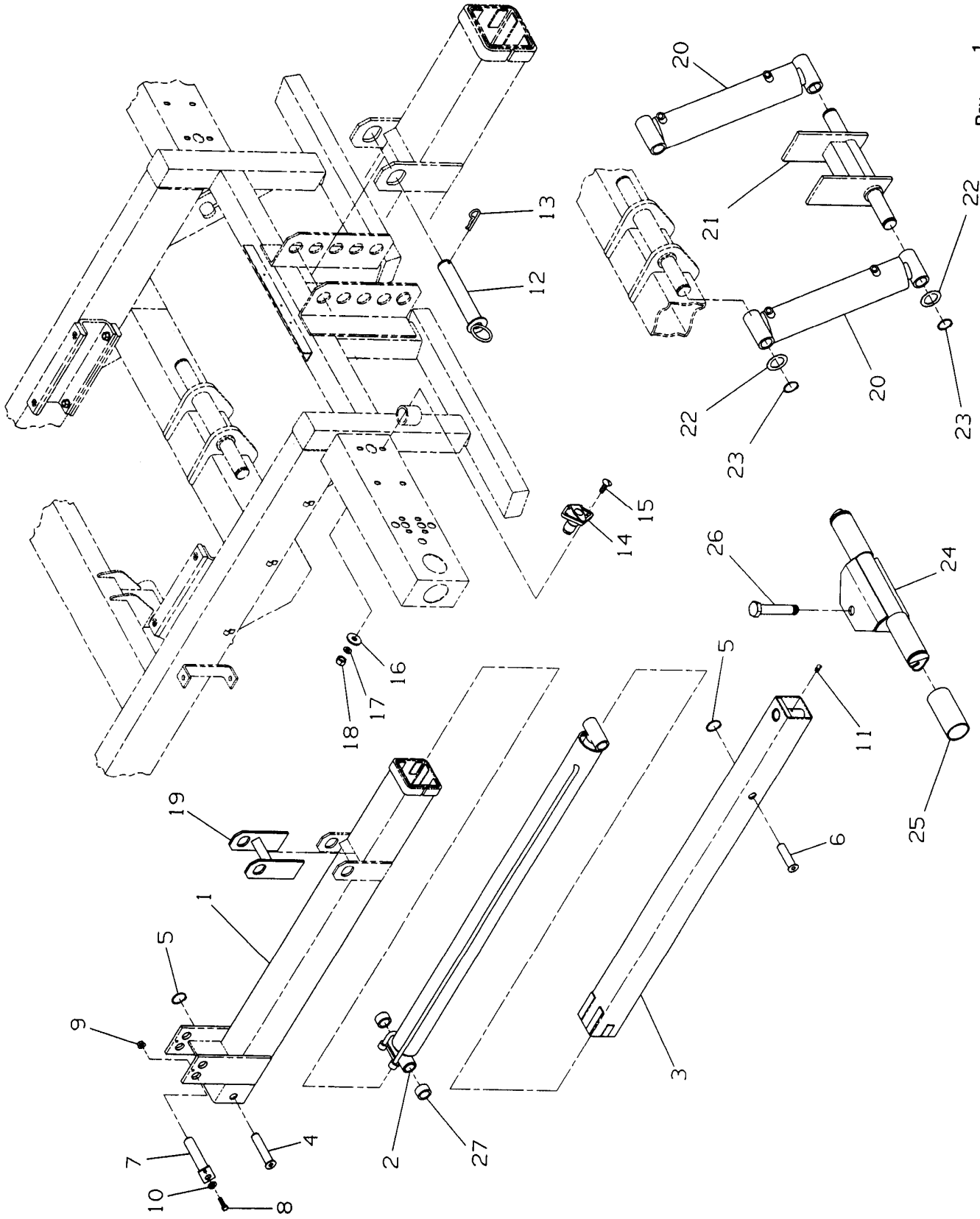

3500# HYDRAULIC WHEEL LIFT TOW BAR  
WITH AND WITHOUT IRL

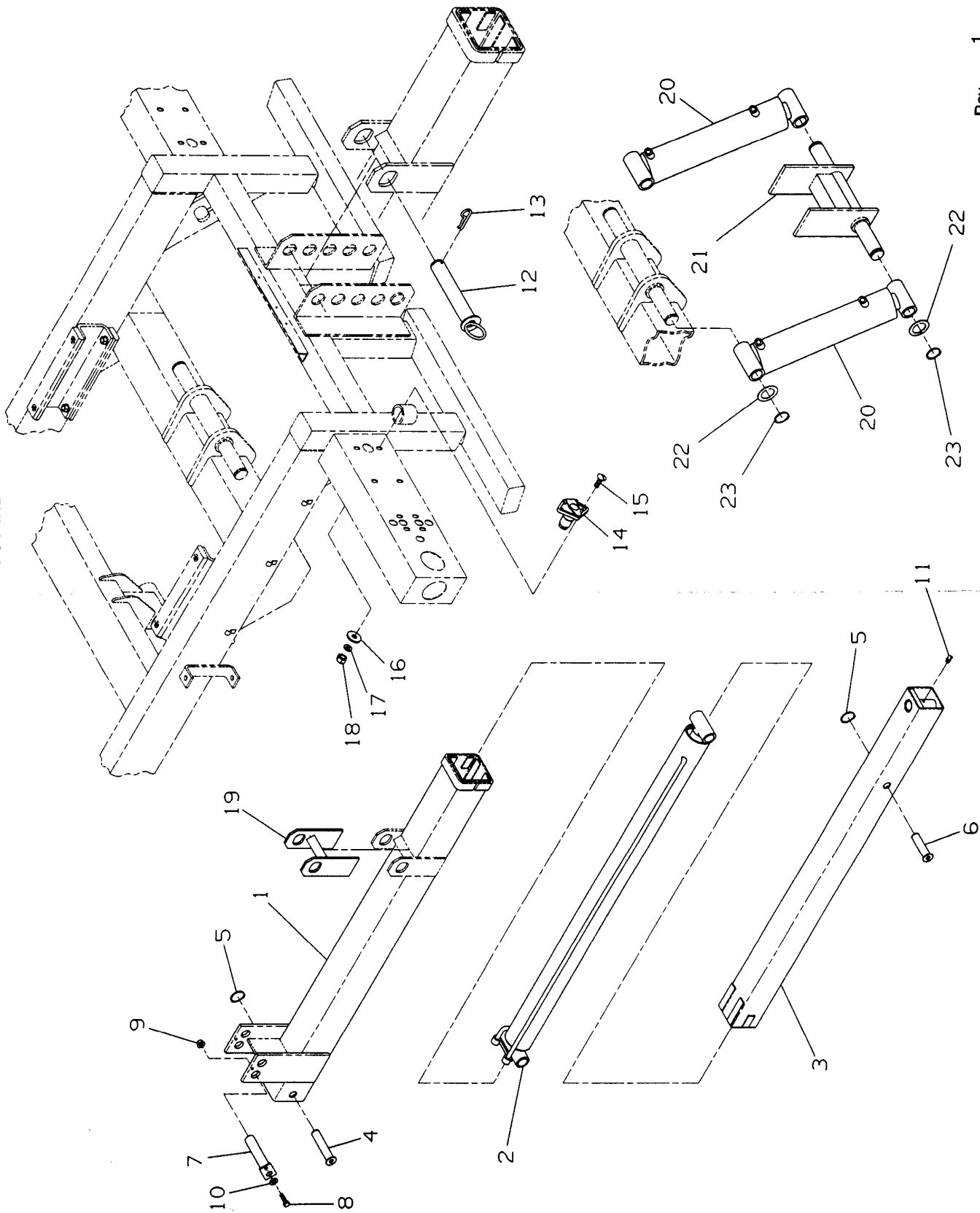

**PARTS LIST — 3500# HYDRAULIC WHEEL LIFT TOW BAR  
WITH AND WITHOUT IRL**

<b>Ref. No.</b>	<b>Part No.</b>	<b>Description</b>	<b>Qty.</b>
1	D3-170-000047	Outer Tube Weldment	1
2	C3-320-000021	Tow Bar Cylinder	1
3	D3-170-000046	Inner Tube Weldment	1
4	A3-691-000042	Pin Weldment	1
5	A7-754-000006	Retaining Ring	2
6	A3-691-000011	Pin Weldment	1
7	3-691-000093	Pin Weldment	1
8	7-115-161250	Hex Head Capscrew	1
9	7-660-162301	Flanged Lock Nut	1
10	7-950-160161	Flat Washer	1
11	7-440-000200	Grease Fitting 45°	1
12	A3-691-000097	Pin Weldment	1
13	A7-691-000001	Hair Pin	1
14	A7-291-000003	Female Receptacle	1
15	7-111-140613	Truss Head Screw	2
16	7-950-140161	Flat Washer	2
17	7-950-140000	Lock Washer	2
18	7-660-140000	Hex Nut	2
19	A3-606-000014	Lug Weldment	1
20	C3-320-000041	IRL Cylinder	2
21	C3-178-000155	Bracket	1
22	A7-949-000008	Washer	4
23	7-754-000014	Retaining Ring	4

Rev. 1

Date 5-1-92

**PARTS LIST — HYDRAULIC TOW BAR WHEEL GRID ASSEMBLY**

<b>Ref. No.</b>	<b>Part No.</b>	<b>Description</b>	<b>Qty.</b>
1	A7-691-000011	Hitch Pin	2
2	A7-894-000002	Tie Down Strap	2
3	C3-511-880049	L-arm	2
4	C3-511-880080	R.H. Grid Weldment	1
5	C3-511-880081	L.H. Grid Weldment	1
6	A3-178-000001	Anchor Bracket	2
7	7-118-182418	Button Head Capscrew	2
8	7-950-180153	Flat Washer	2
9	7-660-181630	Hex Lock Nut	2
10	A4-120-000008	Bolt	1
11	C3-500-880056	Pivot Tube	1
12	7-440-030000	Grease Fitting	2
13	A3-551-000026	T-handle	2

Rev. 1

Date 5-1-92

HYDRAULIC WHEEL LIFT TOW BAR  
WHEEL GRID ASSEMBLY

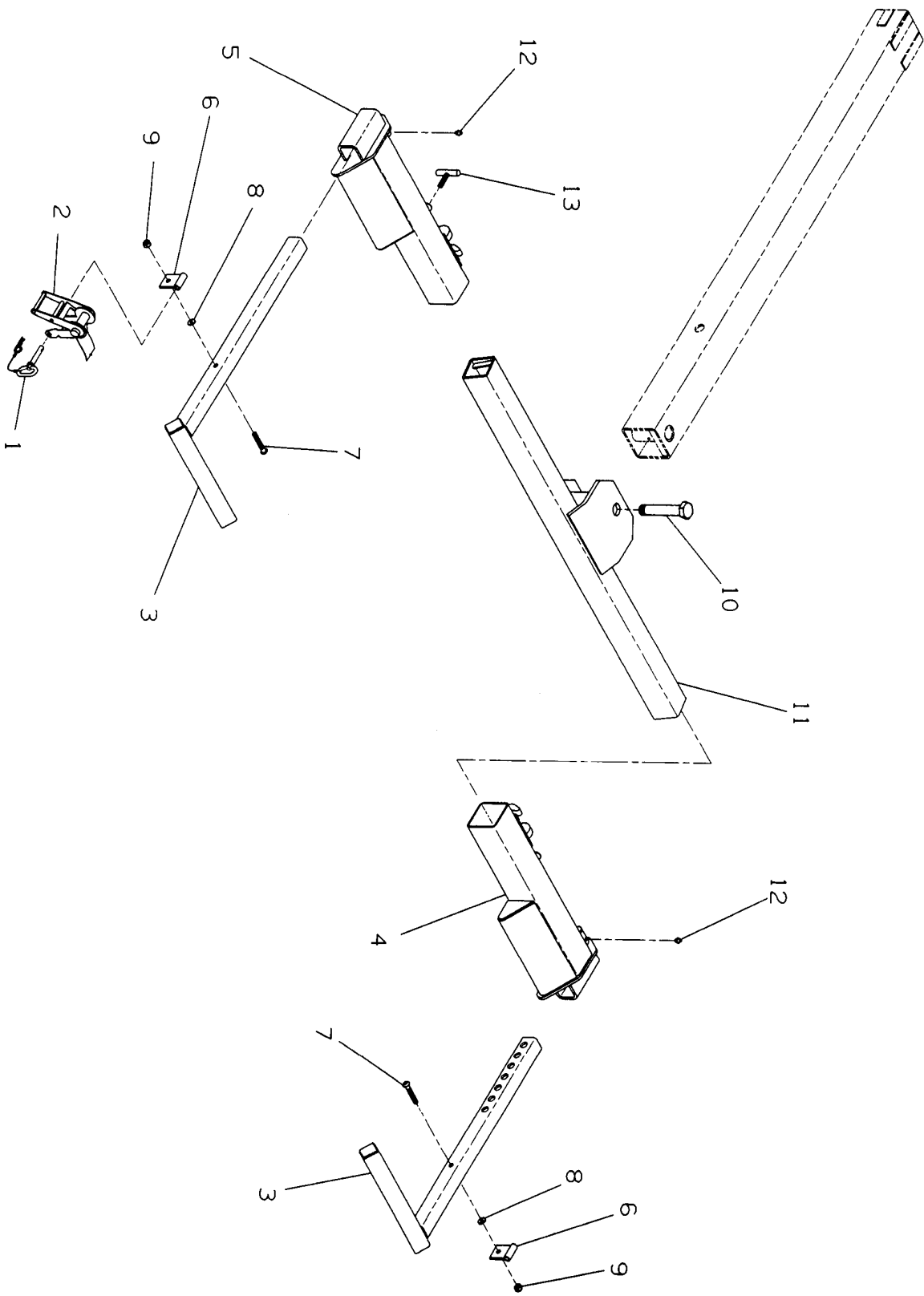

5-375-000072-REV-1

4.14

Rev. 1  
Date 5-1-92

HYDRAULIC COMPONENTS

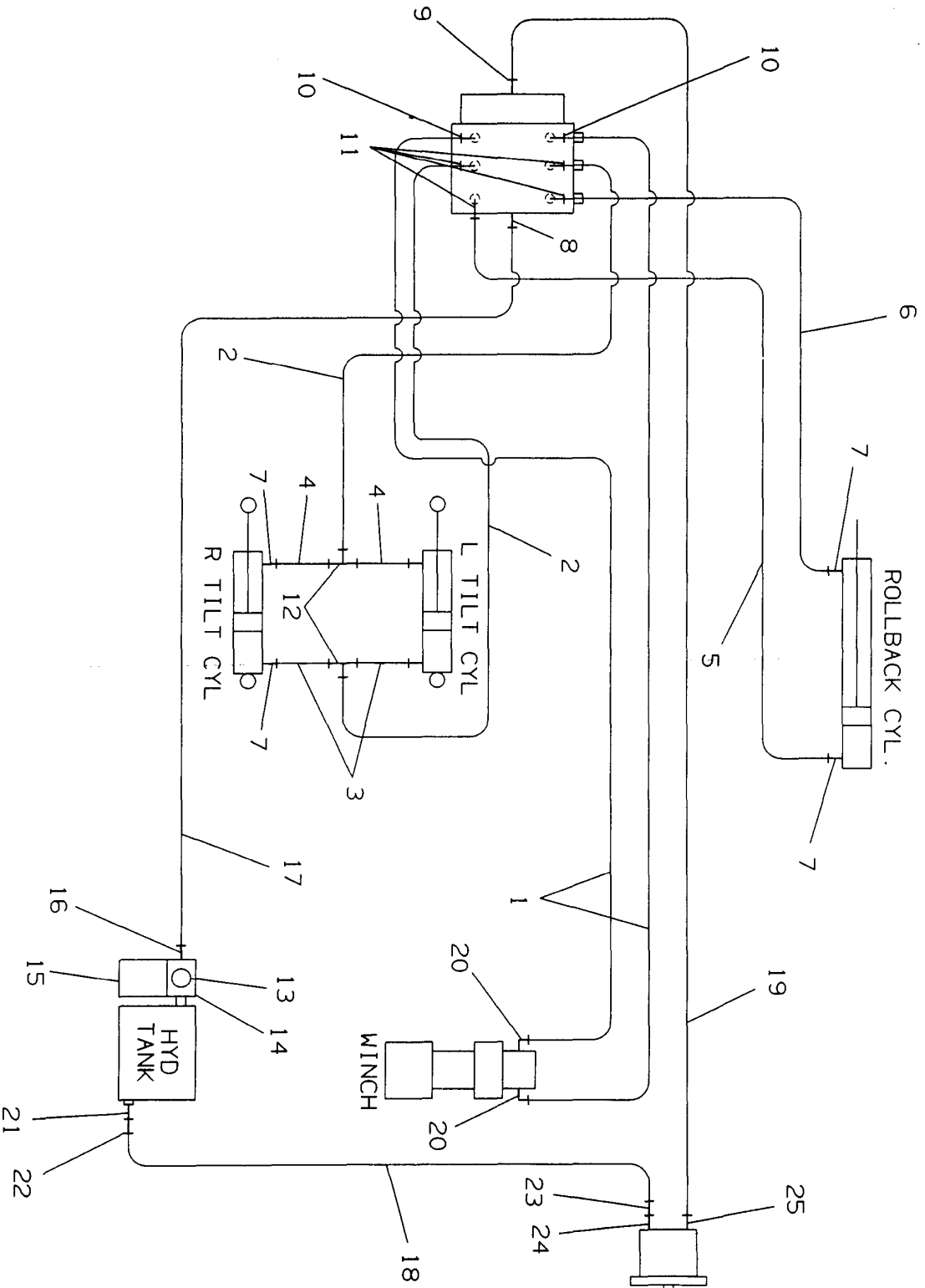



## PARTS LIST — HYDRAULIC COMPONENTS

Ref. No.	Part No.	Description	Qty.
1	4-567-132178	Winch Hose (17' Decks)	2
	4-567-132190*	Winch Hose (18' Decks)	
	4-567-132200*	Winch Hose (19' Decks)	
2	4-567-122097	Tilt Supply Hose	2
3	4-567-120020	Tilt Base Hose	2
4	4-567-120038	Tilt Rod Hose	2
5	4-567-122102	Roll Back Base Hose	1
6	4-567-122043	Roll Back Rod Hose	1
7	7-445-060645	90° Elbow	6
8	7-445-121245	90° Elbow	1
9	7-445-081245	90° Elbow	1
10	7-445-081043	Straight Adapter	2
11	7-445-061043	Straight Adapter	4
12	7-445-060647	Tee	2
13	7-470-000002	Guage	1
14	7-430-000003	Filter Assembly	1
15	A7-431-000001	Filter Element	1
16	**	Fitting	
17	**	Return Hose	1
18	**	Suction Hose	1
19	**	Pressure Hose	1
20	**	Fitting	
21	**	Fitting	
22	**	Fitting	
23	**	Fitting	
24	**	Fitting	
25	**	Fitting	

\* Consult Factory For Foreign Chassis Components

\*\* Consult Factory For Part Numbers and Quantities

Rev. 1

Date 5-1-92

**PARTS LIST — HYDRAULIC COMPONENTS  
HYDRAULIC TOW BAR**

Ref. No.	Part No.	Description	Qty.
1	4-567-132178	Winch Hose (17' Decks)	2
	4-567-132190*	Winch Hose (18' Decks)	
	4-567-132200*	Winch Hose (19' Decks)	
2	4-567-122097	Tilt Supply Hose	2
3	4-567-120020	Tilt Base Hose	2
4	4-567-120038	Tilt Rod Hose	2
5	4-567-122102	Roll Back Base Hose	1
6	4-567-122043	Roll Back Rod Hose	1
7	7-445-060645	90° Elbow	8
8	7-445-121245	90° Elbow	1
9	7-445-081245	90° Elbow	1
10	7-445-081043	Straight Adapter	2
11	7-445-061043	Straight Adapter	6
12	7-445-060647	Tee	2
13	4-567-122030	Tow Bar Supply Hose	2
14	7-470-000002	Guage	1
15	7-430-000003	Filter Assembly	1
16	A7-431-000001	Filter Element	1
17	**	Fitting	
18	**	Return Hose	1
19	**	Suction Hose	1
20	**	Pressure Hose	1
21	**	Fitting	
22	**	Fitting	
23	**	Fitting	
24	**	Fitting	
25	**	Fitting	
26	**	Fitting	

\* Consult Factory For Foreign Chassis Components

\*\* Consult Factory For Part Numbers and Quantities

Rev. 1

Date 5-1-92

H) AULIC COMPONENTS  
HYDRAULIC TOW BAR

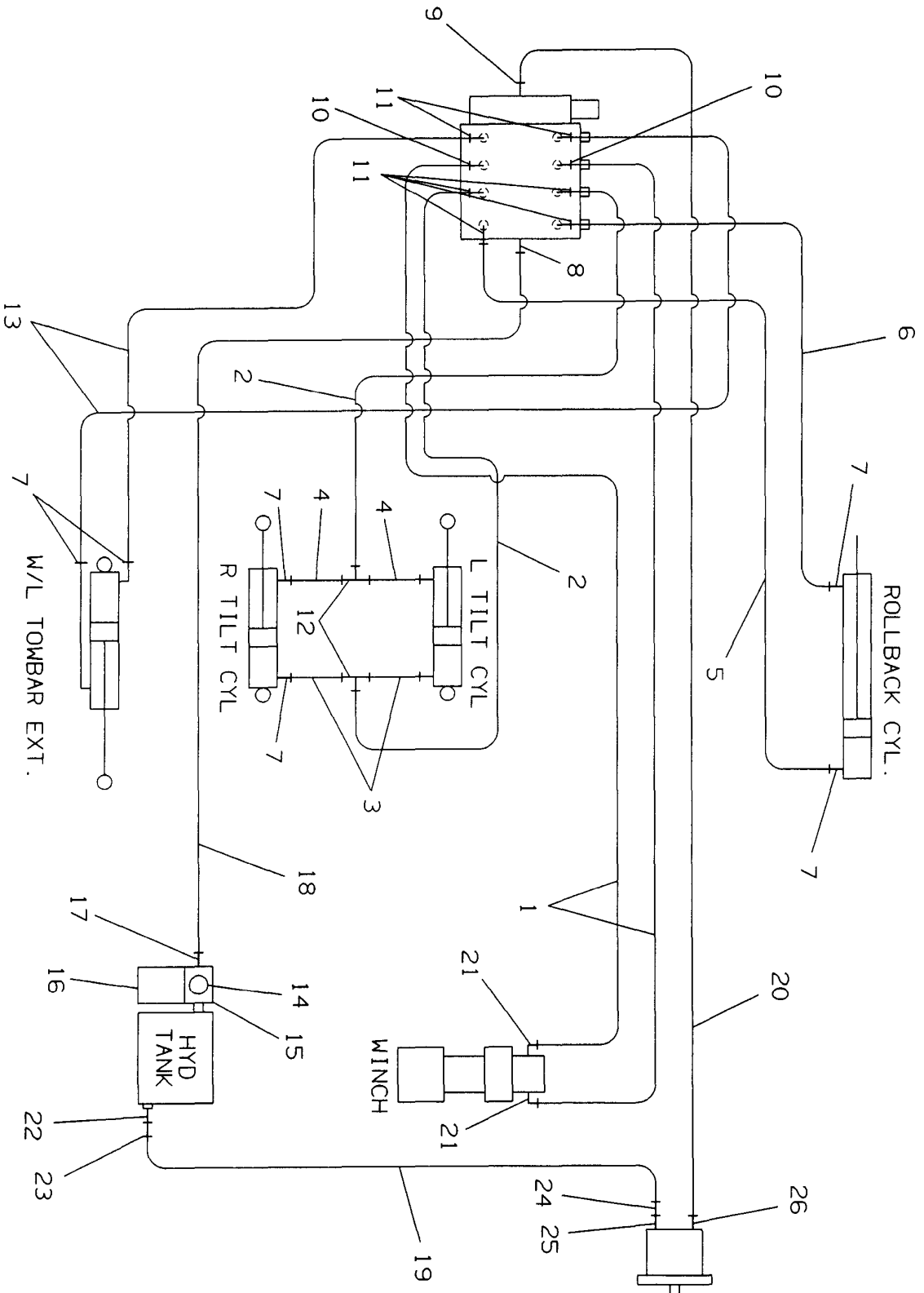

**HYDRAULIC COMPONENTS  
HYDRAULIC TOW BAR WITH IRL**

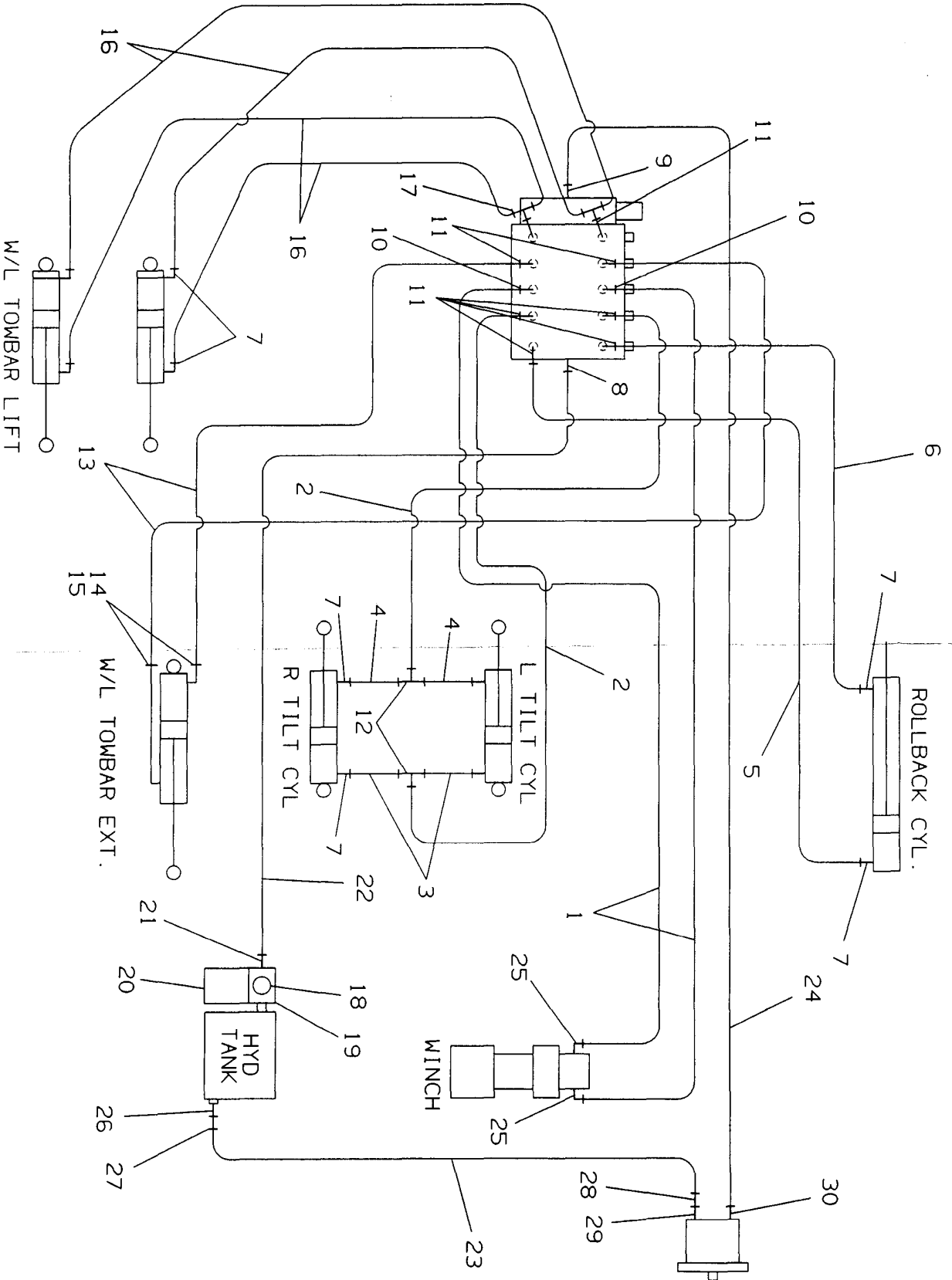

**PARTS LIST — HYDRAULIC COMPONENTS  
HYDRAULIC TOW BAR AND IRL**

Ref. No.	Part No.	Description	Qty.
1	4-567-132178	Winch Hose (17' Decks)	2
	4-567-132190*	Winch Hose (18' Decks)	
	4-567-132200*	Winch Hose (19' Decks)	
2	4-567-122097	Tilt Supply Hose	2
3	4-567-120020	Tilt Base Hose	2
4	4-567-120038	Tilt Rod Hose	2
5	4-567-122102	Roll Back Base Hose	1
6	4-567-122043	Roll Back Rod Hose	1
7	7-445-060645	90° Elbow	10
8	7-445-121245	90° Elbow	1
9	7-445-081245	90° Elbow	1
10	7-445-081043	Straight Adapter	2
11	7-445-061043	Straight Adapter	8
12	7-445-060647	Tee	2
13	4-567-122030	Tow Bar Supply Hose	2
14	7-445-060643	Straight Adapter	2
15	7-445-060672	90° Elbow	2
16	4-567-120038	Tow Bar Lift Supply Hose	4
17	7-443-000078	Tee	2
18	7-470-000002	Guage	1
19	7-430-000003	Filter Assembly	1
20	A7-431-000001	Filter Element	1
21	**	Fitting	
22	**	Return Hose	1
23	**	Suction Hose	1
24	**	Pressure Hose	1
25	**	Fitting	
26	**	Fitting	
27	**	Fitting	
28	**	Fitting	
29	**	Fitting	
30	**	Fitting	

\* Consult Factory For Foreign Chassis Components

\*\* Consult Factory For Part Numbers and Quantities

Rev. 1

Date 5-1-92

## PARTS LIST — LIGHTS AND WIRING

Ref. No.	Part No.	Description	Qty.
1	A7-590-000007	Bar Lamp	1
2	7-790-141056	Self-tapping Screw	2
3	7-345-001703	Terminal Pin	16
4	7-590-000009	Red Light	4
5		Stop-Tail-Turn Light	2
6	A7-590-000011	Work Light	2
7	A7-291-000003	Female Receptacle	1
8	7-111-140613	Truss Head Screw	2
9	7-660-140000	Nut	2
10	7-950-140000	Lock Washer	2
11	7-950-140161	Flat Washer	2
12	A7-590-000012	Light	2
13	D7-552-000005	Wiring Harness	1
14	B7-552-000007	Wiring Harness	1
		(Units Without Emergency Lights)	
	B7-552-000006	Wiring Harness	
		(Units With Emergency Lights)	
15	A7-870-000017	Switch Box	1
16	7-345-211901	Terminal Ring	4
17	7-457-000004	Circuit Breaker	1
18	7-790-100856	Self-tapping Screw	2
19	B7-552-000021	Wiring Harness	1
20	7-590-000010	Amber Light	2
21	B7-552-000009	Wiring Harness	1
22	B7-552-000004	Wiring Harness	1

Rev. \_\_\_\_\_

Date \_\_\_\_\_

# HTS AND WIRING

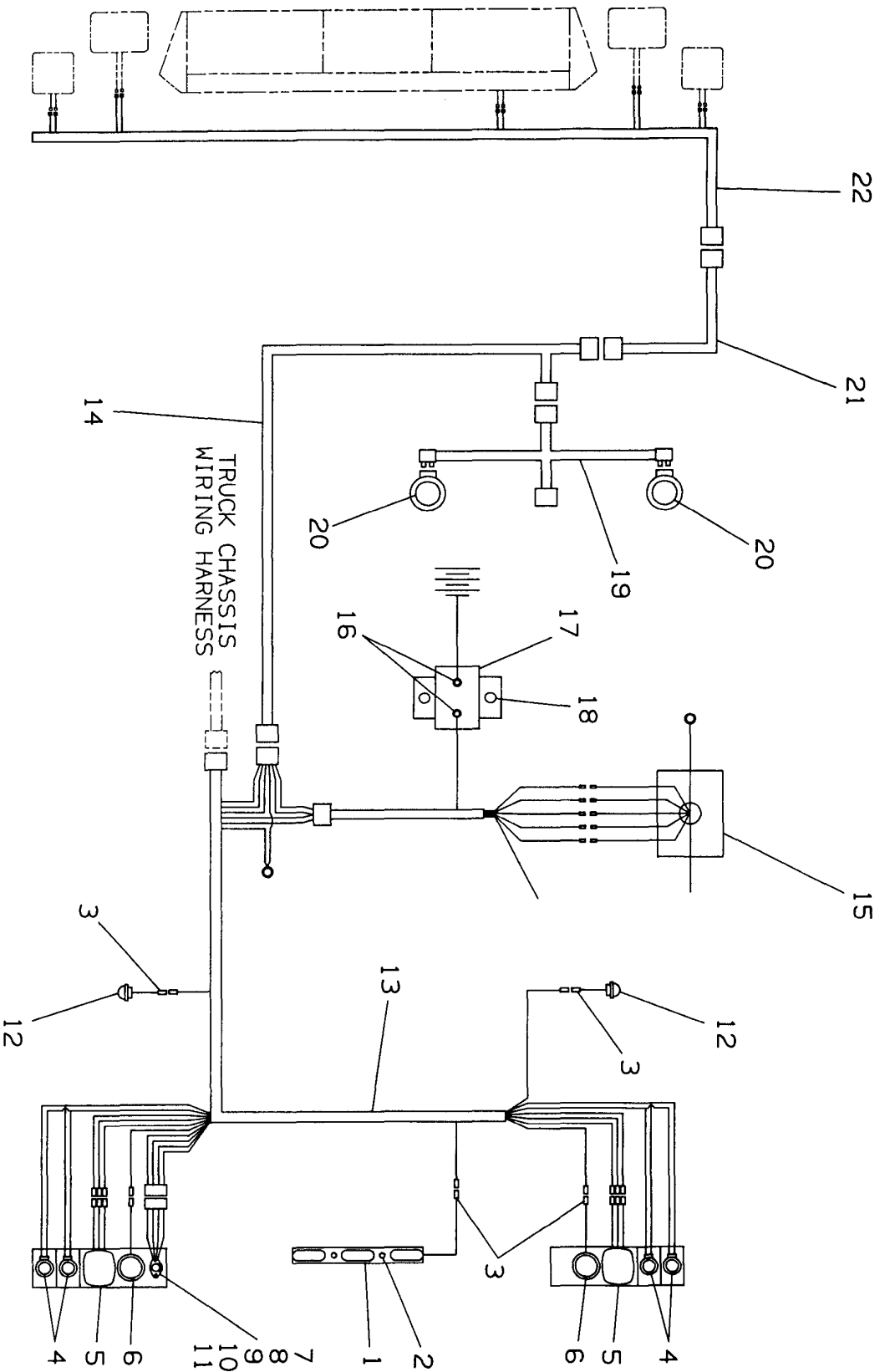

WIRE COLOR	FUNCTION
ORANGE	BEACON LIGHTS
PURPLE	FLOOD LIGHTS
BLUE	TRACTOR LIGHTS
BROWN	PARKING LIGHTS
RED	POWER (HOT)
GREY	EXTRA
BLACK	BACK-UP LIGHTS
GREEN	RIGHT TURN
YELLOW	LEFT TURN
WHITE	GROUND

# PARTS LIST — ROLL BACK CYLINDER

## C3-320-000010

Ref. No.	Part No.	Description	Qty.
1	C3-071-000010	Barrel ("A"=102.38)	1
2	4-763-000106	Rod ("A"=109.50)	1
3	B4-698-000007	Piston	1
4	B4-553-000008	Head	1
5	7-754-000003*	Ring, Wear	2
6	7-754-000004*	Ring, Wear	1
7	7-796-000006*	Seal, Piston	1
8	7-796-000024*	Seal, Rod	1
9	7-755-224000*	"O" Ring	1
10	7-755-334000*	"O" Ring	1
11	7-796-000008*	Seal, Rod Wiper	1
12	7-754-000002*	Ring, Retaining	1
13	7-660-262031	Lock Nut	2
14	7-755-334609*	Ring, Back-up	1
15	7-755-224609*	Ring, Back-up	2
16	7-754-000026	Ring, Retaining	1

\* Available only in service kit #7-577-250024

Rev. \_\_\_\_\_

4.23

Date \_\_\_\_\_



# ROLL BACK CYLINDER

C3-320-000010

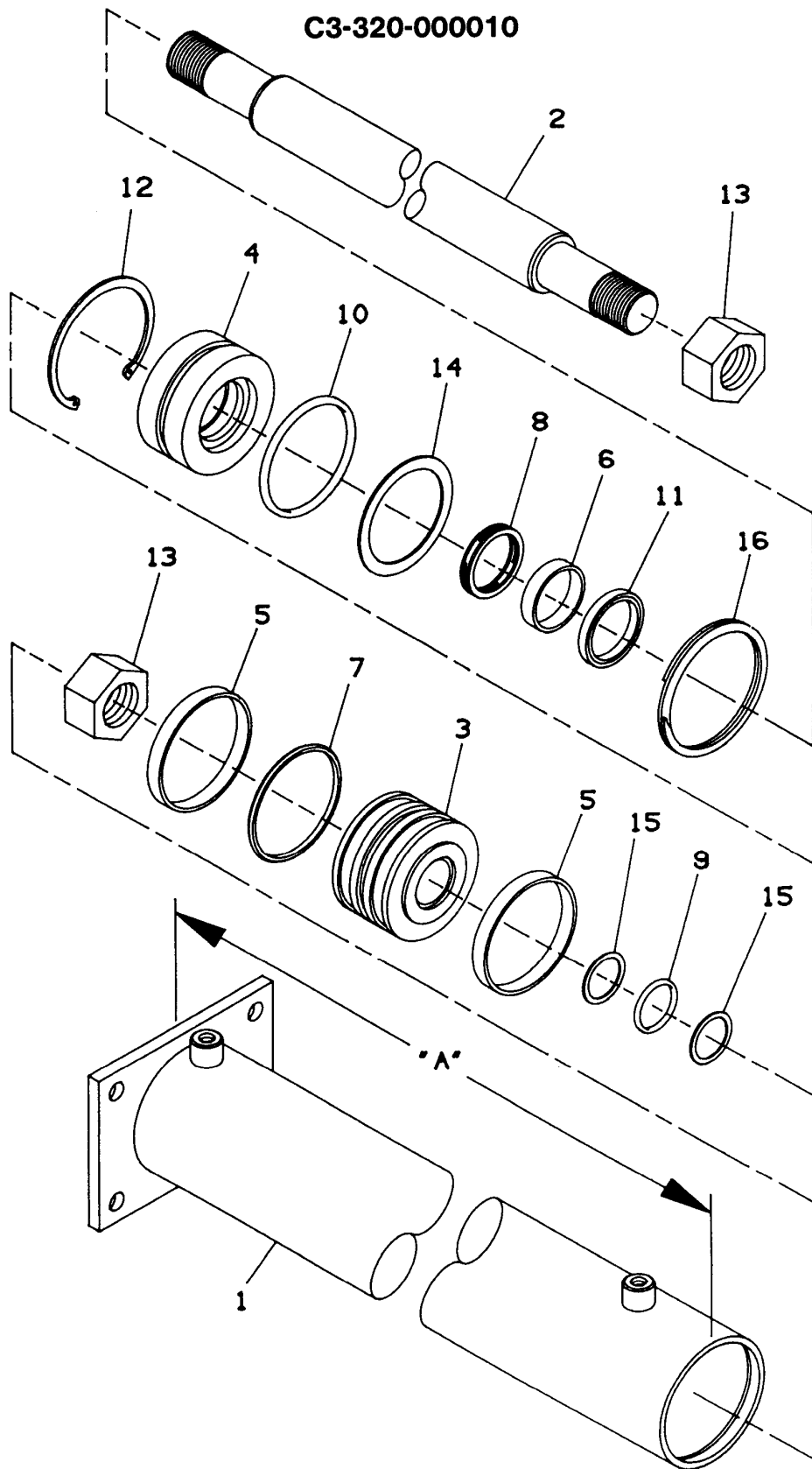

# PARTS LIST — TILT CYLINDER

C3-320-000009

Ref. No.	Part No.	Description	Qty.
1	3-071-000009	Barrel Weldment	1
2	3-763-000033	Rod	1
3	B4-698-000007	Piston	1
4	B4-553-000008	Head	1
5	A7-754-000003*	Ring, Wear	2
6	A7-754-000004*	Ring, Wear	1
7	A7-796-000006*	Seal, Piston 'T'	1
8	A7-796-000024*	Seal, Rod	1
9	7-755-224000*	"O" Ring	1
10	7-755-334000*	"O" Ring	1
11	A7-796-000008*	Seal, Rod Wiper	1
12	A7-754-000002*	Ring, Retaining	1
13	7-660-262031	Nut, Lock	1
14	7-440-000000	Fitting, Grease	1
15	7-440-000200	Fitting, Grease 45°	1
16	7-755-334609*	Ring, Backup	1
17	7-755-224609*	Ring, Backup	2
18	7-754-000026*	Ring, Retaining	1

\* Available only in Service Kit #7-577-250024.

TILT CYLINDER  
C3-320-000009

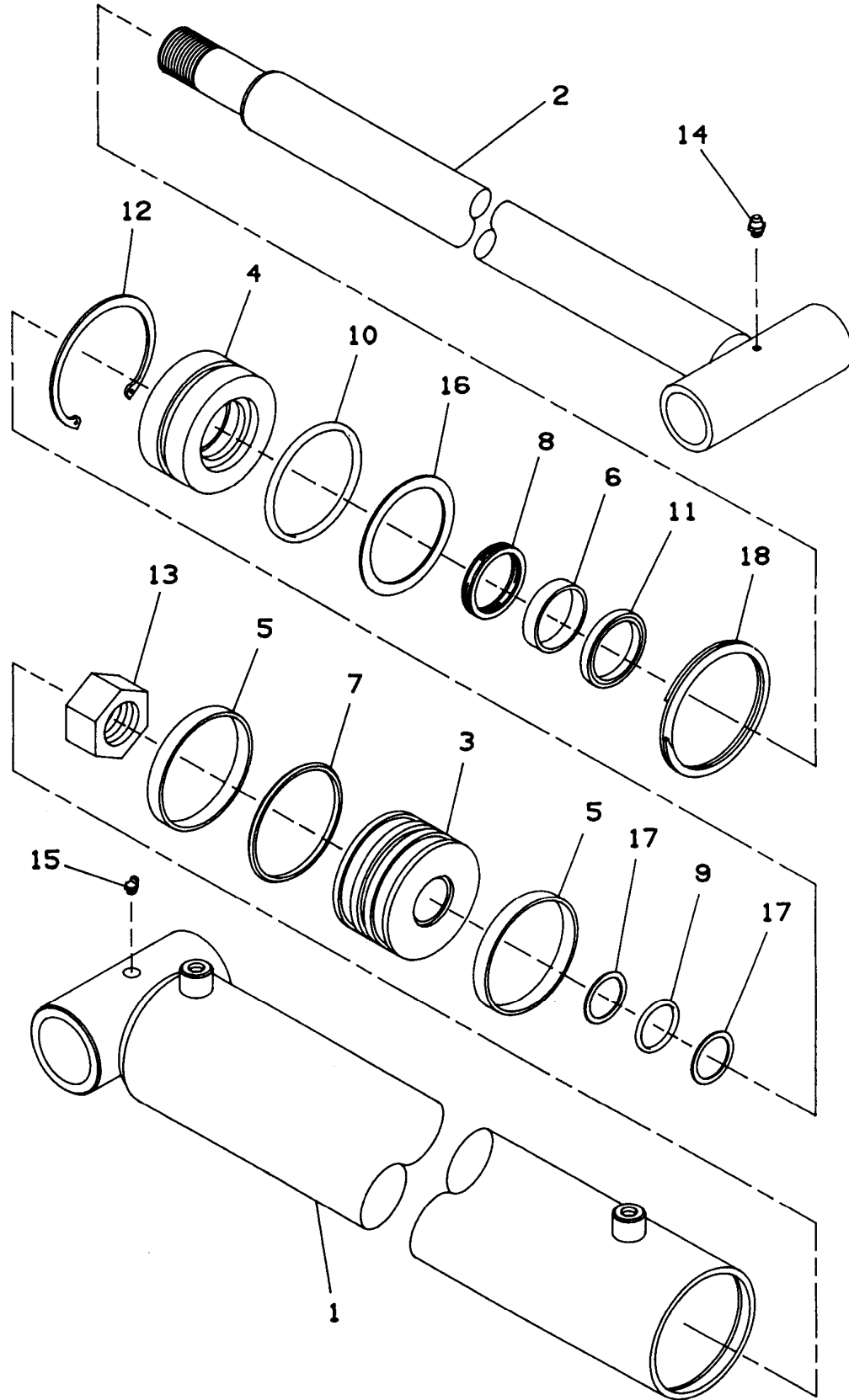

**PARTS LIST — TOW BAR CYLINDER**

**C3-320-000013**

Ref. No.	Part No.	Description	Qty.
1	C3-071-000014	Barrel	1
2	3-763-000034	Rod	1
3	B4-698-000011	Piston	1
4	B4-553-000011	Head	1
5	7-796-000026*	Seal, Piston	1
6	7-755-214000*	"O" Ring	1
7	7-755-327000*	"O" Ring	1
8	7-796-000023*	Seal, Rod	1
9	A7-796-000005*	Seal, Wiper	1
10	7-754-000001*	Ring, Retaining	1
11	7-796-000030*	Ring, Wear	2
12	7-754-000036*	Ring, Wear	1
13	7-660-202031	Lock Nut	1
14	7-755-327609*	Ring, Back-up	1
15	7-755-214609*	Ring, Back-up	2
16	7-754-000026*	Ring, Retaining	1

\* Available only in service kit #7-577-250023

**PARTS LIST — TOW BAR CYLINDER**

**C3-320-000020**

Ref. No.	Part No.	Description	Qty.
1	C3-071-000020	Barrel	1
2	3-763-000035	Rod	1
3	B4-698-000007	Piston	1
4	B4-553-000008	Head	1
5	A7-796-000006*	Seal, Piston	1
6	7-755-224000*	"O" Ring	1
7	7-755-334000*	"O" Ring	1
8	A7-796-000024*	Seal, Rod	1
9	A7-796-000008*	Seal, Wiper	1
10	A7-754-000002*	Ring, Retaining	1
11	A7-754-000003*	Ring, Wear	2
12	A7-754-000004*	Ring, Wear	1
13	7-660-262031	Lock Nut	1
14	7-755-334609*	Ring, Back-up	1
15	7-755-224609*	Ring, Back-up	2
16	7-754-000026*	Ring, Retaining	1

\* Available only in service kit #7-577-250024

Rev. 1

4.27

Date 5-1-92

TOW BAR CYLINDER  
C3-320-000013  
C3-320-000020

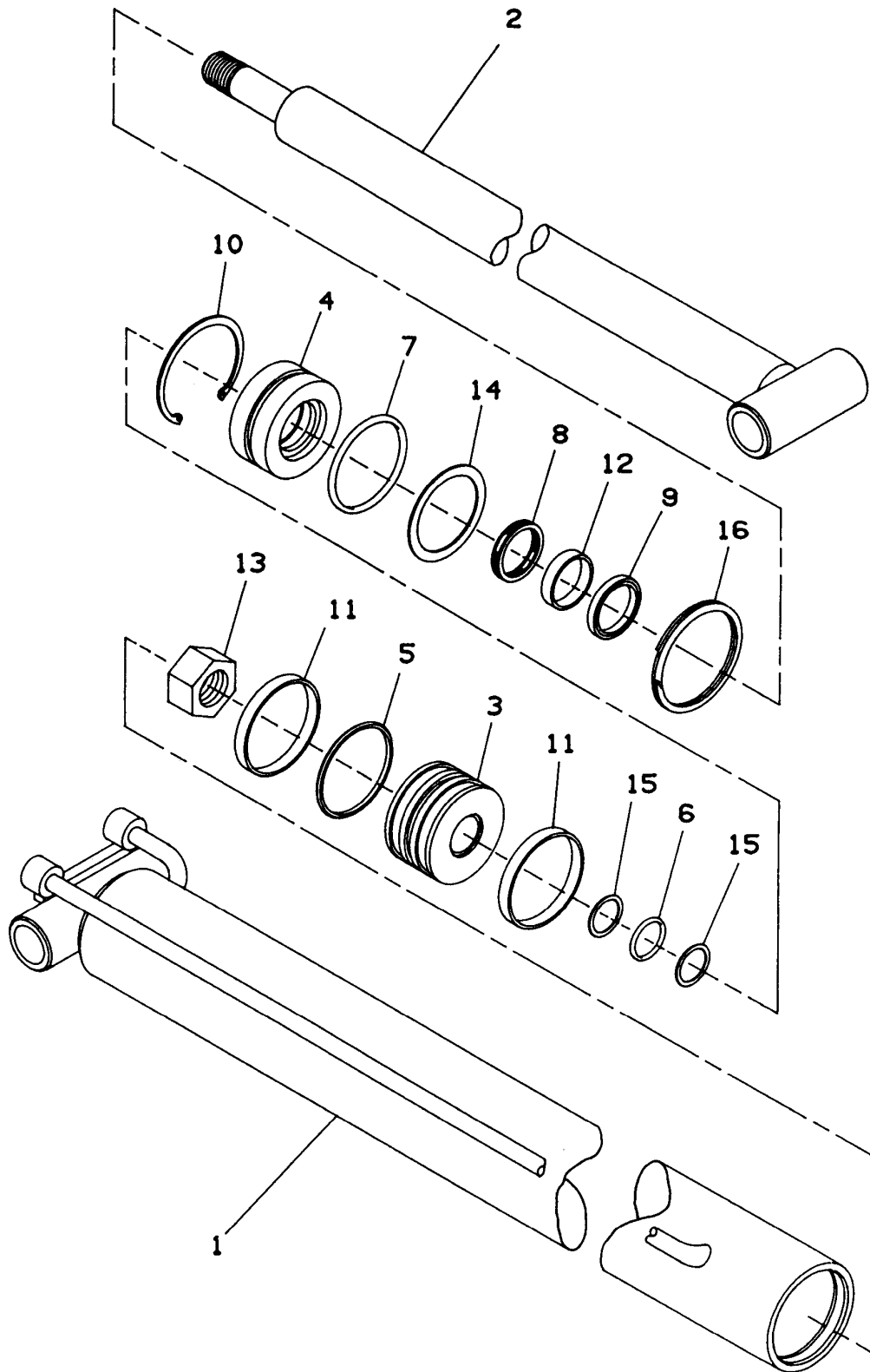

**PARTS LIST — WHEEL LIFT TOW BAR CYLINDER**

**C3-320-000021**

<b>Ref. No.</b>	<b>Part No.</b>	<b>Description</b>	<b>Qty.</b>
1	C3-071-000021	Barrel	1
2	B3-763-000036	Rod	1
3	B4-698-000007	Piston	1
4	B4-553-000008	Head	1
5	A7-796-000006*	Seal, Piston 'T'	1
6	7-755-224000*	"O" Ring	1
7	7-755-334000*	"O" Ring	1
8	A7-796-000024*	Seal, Rod	1
9	A7-796-000008*	Seal, Rod Wiper	1
10	A7-754-000002*	Ring, Retaining	1
11	A7-754-000003*	Ring, Wear	1
12	A7-754-000004*	Ring, Wear	1
13	7-660-262031	Lock Nut	1
14	7-755-334609*	Ring, Back-up	1
15	7-755-224609*	Ring, Back-up	2
16	7-754-000026*	Ring, Retaining	1

\* Available only in service kit #7-577-250024

# WHEEL LIFT TOW BAR CYLINDER

C3-320-000021

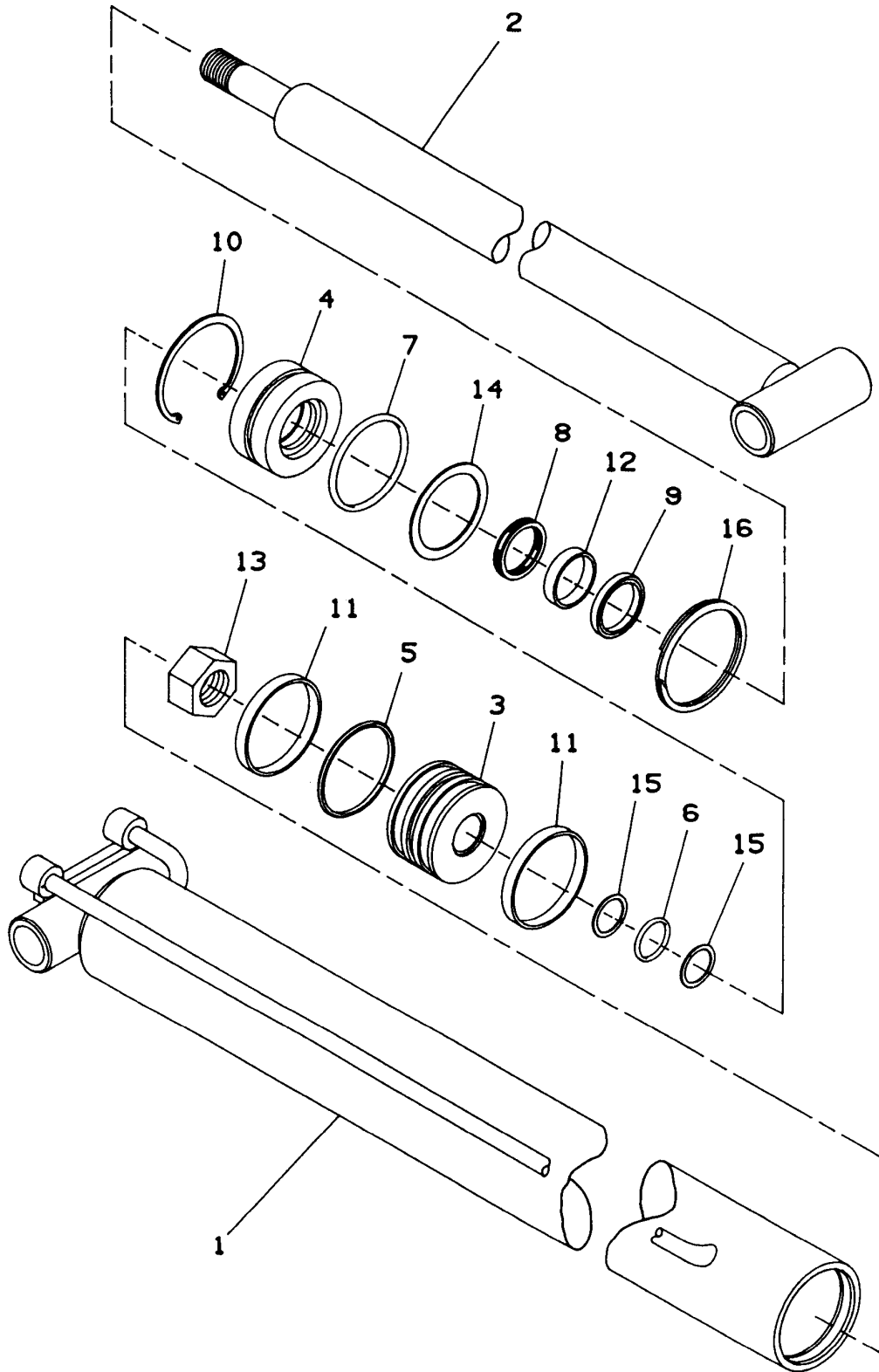

## PARTS LIST — IRL CYLINDER

C3-320-000041

Ref. No.	Part No.	Description	Qty.
1	C3-071-000040	Barrel	1
2	3-763-000053	Rod	1
3	B4-698-000007	Piston	1
4	B4-698-000008	Head	1
5	A7-754-000003*	Ring, Wear	2
6	A7-754-000004*	Ring, Wear	1
7	A7-796-000006*	Seal, Piston "T"	1
8	A7-796-000024*	Seal, Rod	1
9	7-755-224000*	"O" Ring	1
10	7-755-334000*	"O" Ring	1
11	A7-796-000008*	Seal, Wiper	1
12	A7-754-000002*	Ring, Retaining	1
13	7-660-262031	Nut, Lock	1
14	7-440-000200	Fitting, Grease 45°	1
15	7-440-000000	Fitting, Grease	1
16	7-755-334609*	Ring, Back-up	1
17	7-755-224609*	Ring, Back-up	2
18	7-754-000026*	Ring, Retaining	1

\* Available only in service kit #7-577-250024



**IRL CYLINDER  
C3-320-000041**

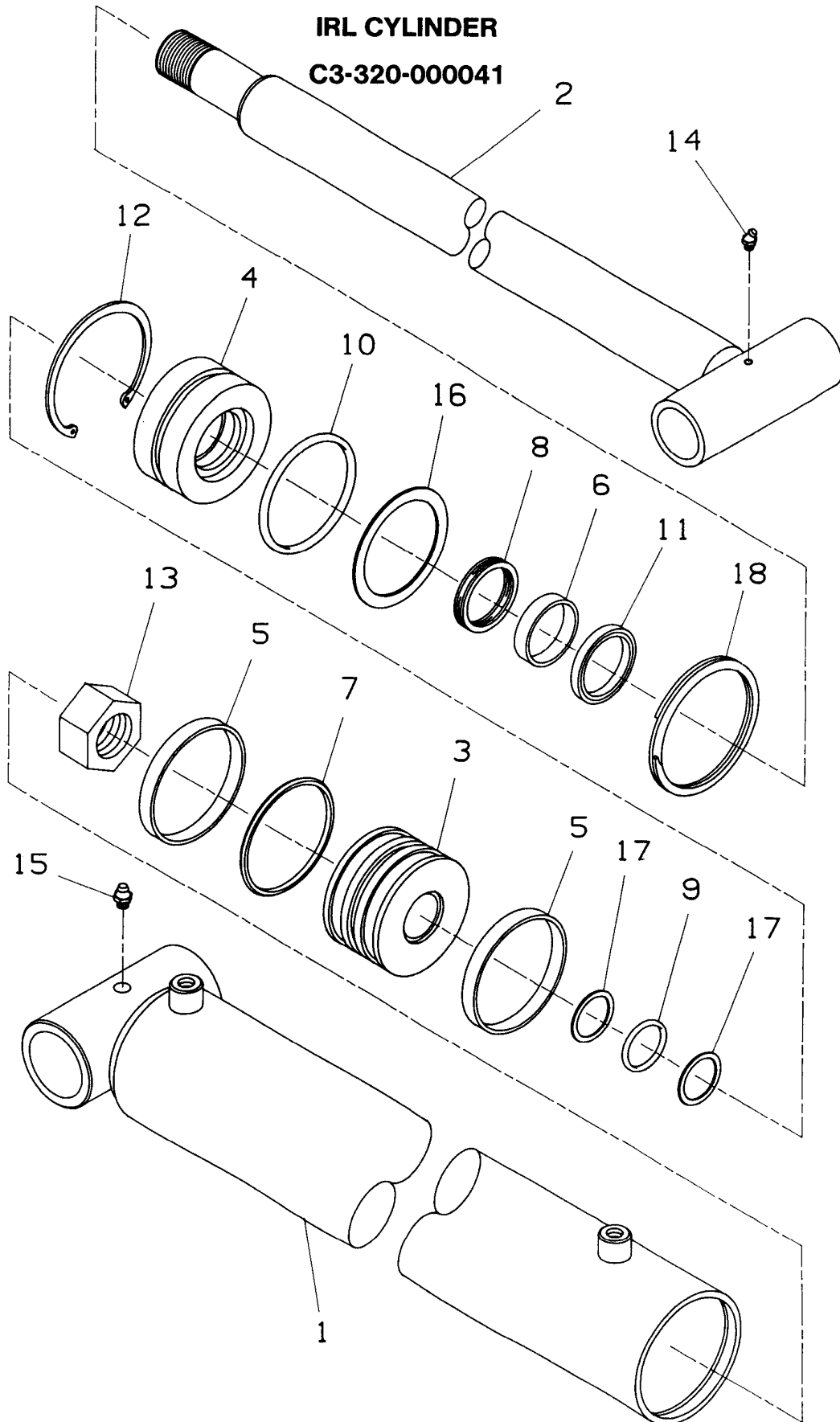

# WINCH ASSEMBLY (8,000 LB. WORM GEAR)

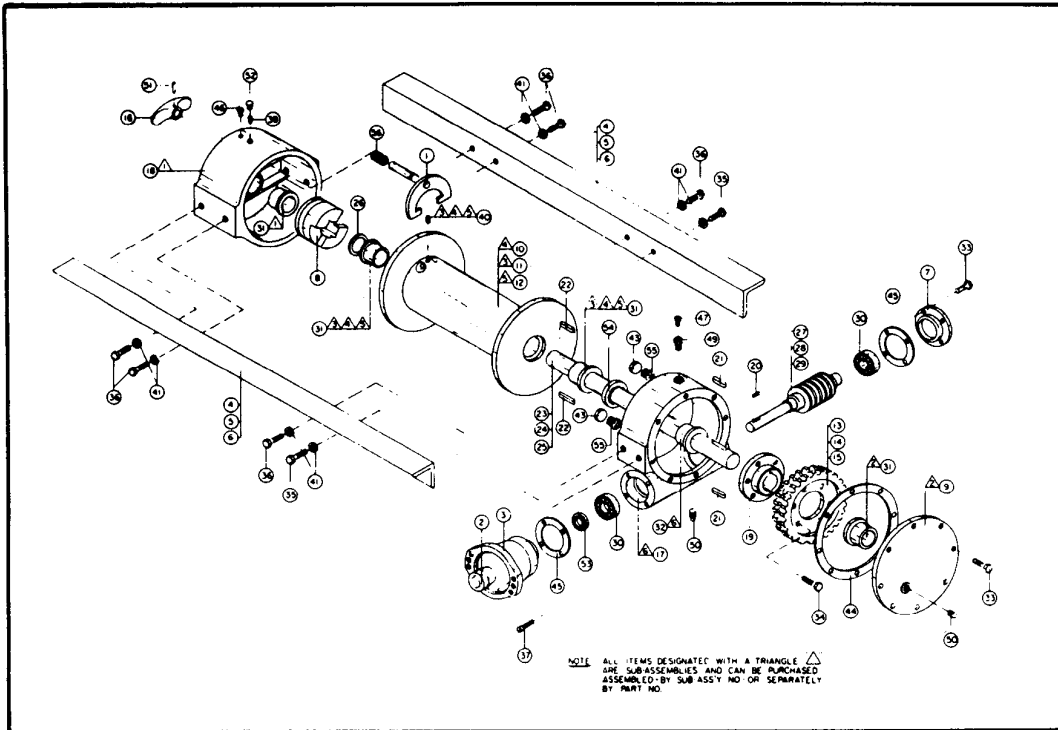

## MATERIAL LISTING

ITEM NO.	QTY REQD.	PART NO.	DESCRIPTION	ITEM NO.	QTY REQD.	PART NO.	DESCRIPTION	ITEM NO.	QTY REQD.	PART NO.	DESCRIPTION
1	1	276028	Shifter Ass'y.	27	1	368002	Worm 46:1 Ratio	41	8	418177	Lockwasher 3/8 Med. Section
2	1	299037	Coupling Ass'y.	28	1	368007	Worm 60:1 Ratio				
3	1	300037	Adapter	29	1	368011	Worm 30:1 Ratio				
4	2	302421	Angle "Std's"	30	2	402002	Ball Bearing				
5	2	302423	Angle "Y" Mod's.	31	4	412003	Bushing	43	2	438001	Drag Brake
6	2	302525	Angle "B" Mod's.	32	1	412007	Bushing	44	1	442001	Gasket
7	1	316083	Bearing Caps	33	12	414049	Capscrew 1/4-20NC x 3/4 Hx. Hd. C.P.	45	2	442002	Gasket
8	1	324137	Jaw Clutch	34	6	414110	Capscrew 5/16-18NC x 3/4 Hx. Hd.	46	1	456001	Lub Fitting
9	1	328105	Cover	35	2	414309	Capscrew 3/8-16NC x 3/4 Hx. Hd. C.P.	47	1	456008	Relief Fitting
10	1	332002	Drum "B" Mod.	36	6	414310	Capscrew 3/8-16NC x 1 Hx. Hd. C.P.	49	1	468002	Reducer
11	1	332005	Drum "Std's"	37	4	414842	Capscrew 1/4-20NC x 1 3/4 Hx. Soc. Hd.	50	2	468011	Pipe Plug
12	1	332079	Drum "Y" Mod.					51	1	470033	Spiral Pin
13	1	334004	Gear 60:1 Ratio	39	1	416030	Setscrew 1/4-20NC x 3/8 Hx. Soc. Hd. Less-Full Dog Point	52	1	472012	Plug-Rubber
14	1	334005	Gear 46:1 Ratio	40	1	416057	Setscrew 3/8-16NC x 3/8 fix. Soc. Hd. Less-Full Dog Point	53	1	486009	Oil Seal
15	1	334020	Gear 30:1 Ratio					54	1	486017	Oil Seal
16	1	338010	Handle					55	2	494002	Spring
17	1	338017	Housing-Gear					56	1	494053	Spring
18	1	338208	Housing-Clutch								
19	1	340001	Hub-Gear								
20	1	342029	Key								
21	2	342075	Key								
22	2	450006	Key (Barth)								
23	1	357403	Shaft-Drum "Std's"								
24	1	357405	Shaft-Drum "Y"								
25	1	357406	Shaft-Drum "B"								
26	1	368016	Spacer								

## SUB ASSEMBLY LISTING

ITEM NO.	QTY REQD.	PART NO.	DESCRIPTION	ITEM NO.	QTY REQD.	PART NO.	DESCRIPTION
Δ	1	222038	Clutch Ass'y	Δ	1	234080	Drum Ass'y. ("Y")
Δ	1	228055	Cover Ass'y. (G.H.)	Δ	1	258006	Gear Hg. Ass'y.
Δ	1	234004	Drum Ass'y. (Std.)				
Δ	1	234019	Drum Ass'y. ("B")				

Rev. \_\_\_\_\_

4.33

Date \_\_\_\_\_

**WINC-11 ASSEMBLY  
(8,000 PLANETARY)**

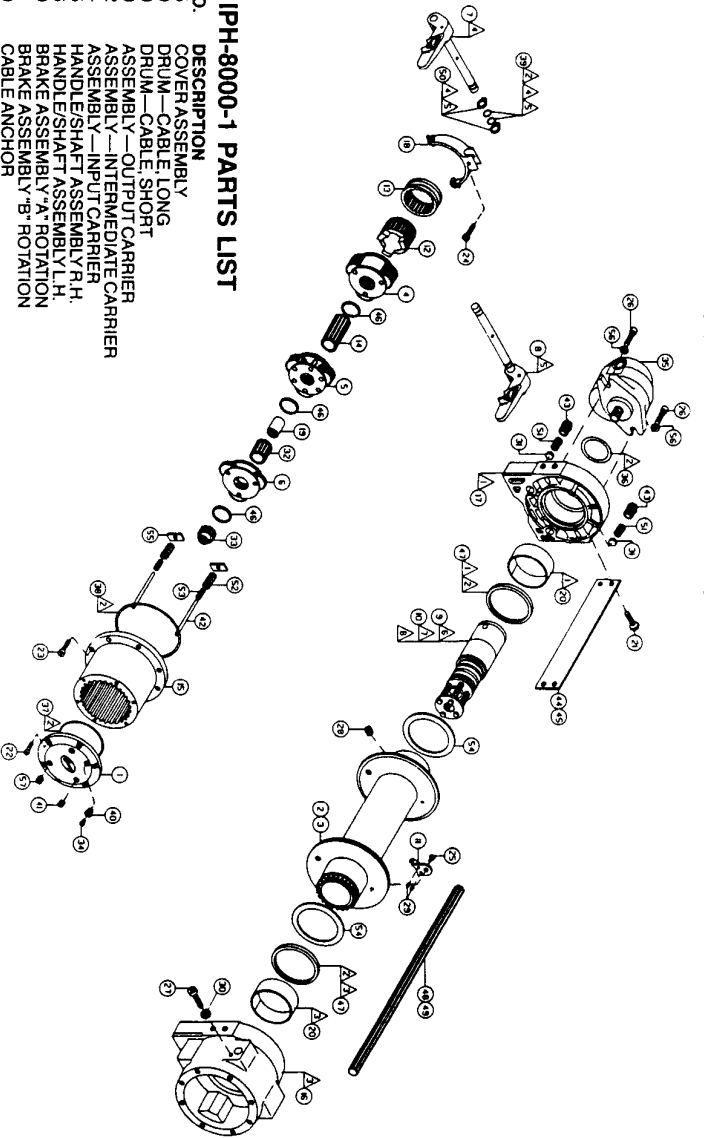

**IPH-8000-1 PARTS LIST**

ITEM NO.	QTY.	PART NO.	DESCRIPTION
1	1	228075	COVER ASSEMBLY
2	1	234149	DRUM—CABLE LONG
3	1	234150	DRUM—CABLE SHORT
4	1	247010	ASSEMBLY—OUTPUT CARRIER
5	1	247012	ASSEMBLY—INTERMEDIATE CARRIER
6	1	247014	ASSEMBLY—INPUT CARRIER
7	1	276045	HANDLE/SHAFT ASSEMBLY R.H.
8	1	276046	HANDLE/SHAFT ASSEMBLY L.H.
9	1	296290	BRAKE ASSEMBLY "A" ROTATION
10	1	296291	BRAKE ASSEMBLY "B" ROTATION
11	1	299680	CABLE ANCHOR
12	1	324271	COUPLING—CLUTCH
13	1	324323	RING—LOCKING
14	1	334160	GEAR—SUN OUTPUT
15	1	334160	GEAR—RING
16	1	338284	END BEARING—GEAR HOUSING
17	1	338285	END BEARING—MOTOR
18	1	370053	YOKE
19	1	412073	BUSHING—INPUT SHAFT
20	2	412074	BUSHING—DRUM
21	8	414620	CAPSCREW 1/2"—13NC x 1 LG. HX. HD. GR.5 LOK-WEL
22	6	414848	CAPSCREW 1/2"—20NC x 1 LG. SOC. HD. LOK-WEL
23	8	414869	CAPSCREW 5/8"—18NC x 1 LG. SOC. HD. LOK-WEL
24	1	414871	CAPSCREW 5/8"—18NC x 1 1/2 LG. SOC. HD. LOK-WEL
25	1	414871	CAPSCREW 1/2"—20NC x 1/2 LG. FLAT SOC. HD. LOK-WEL
26	2	414822	CAPSCREW 3/8"—16NC x 1 LG. SOC. HD. NY LOK
27	1	414830	CAPSCREW 3/8"—16NC x 2 1/4 LG. SOC. HD.
28	1	416028	SETScrew 1/4"—20NC x 1/2 LG. CUP PT. LOK-WEL
29	2	416050	SETScrew 5/16"—24NF x 1/2 LG. CUP PT.
30	1	418036	NUt 3/8"—16NC JAM
31	2	438014	DISC—DRAG BRAKE
32	1	444062	GEAR—SUN, INTERMEDIATE
33	1	444063	GEAR—SUN, INPUT
34	1	456008	BREATHER
35	1	458065	MOTOR—HYDRAULIC
36	1	462028	O-RING .06 WD. x .380 O.D. x .325 I.D.
37	1	462030	O-RING .103 SQ. x .3875 I.D.
38	1	462031	O-RING .09 WD. x .634 O.D. x .675 I.D.
39	1	462037	O-RING .06 WD. x .62 O.D. x .50 I.D.
40	1	468002	REDUCER
41	1	468018	PLUG 3/4"—18NPT SOC. HD.
42	2	472018	PIN—CLUTCH SPRING
43	2	472018	PLUG—DRAG BRAKE
44	2	474056	TIE PLATE—LONG DRUM
45	2	474065	TIE PLATE—SHORT DRUM

ITEM NO.	QTY.	PART NO.	DESCRIPTION
46	2	477005	RING—THRUST
47	1	486075	LIP SEAL
48	1	489013	SHAFT—INPUT, LONG DRUM
49	1	489014	SHAFT—INPUT, SHORT DRUM
50	2	490001	RING—SNAP, EXTERNAL 5/8 I.D.
51	2	494002	SPRING—DRAG BRAKE
52	2	494082	SPRING—CLUTCH
53	2	494086	SPRING—CLUTCH
54	2	518029	WASHER—DRUM
55	2	518031	WASHER—YOKE SPRING
56	2	418181	WASHER—3/8 SAE FLAT
57	1	468030	PLUG 3/4"—18NPT SOC. HD.—MAGNETIC

**SUB-ASSEMBLIES IPH-8000-1**

ITEM NO.	QTY.	PART NO.	DESCRIPTION
△	1	202009	END BEARING ASSY.—MOTOR
△	1	246036	SEAL KIT (ALL SEALS)
△	1	248049	HOUSING ASSY.—CLUTCH
△	1	276043	HANDLE ASSY. R.H.
△	1	276044	HANDLE ASSY. L.H.
△	1	256044	BRAKE ASSEMBLY KIT—"A" ROTATION
△	1	256045	BRAKE ASSEMBLY KIT—"B" ROTATION
△	1	256046	FRICITION DISC KIT

ITEMS DESIGNATED WITH A TRIANGLE "△" ARE  
SUB-ASSEMBLIES AND CAN BE PURCHASED BY  
SUB-ASSEMBLY NUMBER.