

\$35.00

**MPL
MPL40
UNDERLIFT LEVEL STOP
SUPPLEMENT MANUAL**

JERR-DAN[®]

An Oshkosh Corporation Company

1080 Hykes Road
Greencastle, PA 17225
Phone (717) 597-7111
www.jerr-dan.com

5-376-000103
REV. 0 - 06/07

© 2006 Jerr-Dan Corporation. All Rights Reserved.

THIS PAGE INTENTIONALLY LEFT BLANK

FOREWORD

This manual is intended to serve as a guide to the owner and operator in the safe operation and optimum performance of this Jerr-Dan equipment.

Establishment of good operating habits and familiarity with the equipment and its capabilities combined with good judgement are essential.

Before attempting to operate the unit carefully read all sections of this manual.

This manual should be kept with the equipment at all times and referred to whenever in doubt of proper operation.

Information contained in this manual reflects how this vehicle was built at the factory. Modifications or additions by the distributor or owner are not reflected in this manual.

This manual does not include operation and maintenance information for the commercial chassis (International, Ford, GM, etc.). This information is provided by the chassis manufacturer.

When inquiring about operation, maintenance or warranty, please have ready your equipment's Sales Order Number, Serial Number and Model Number. This information can be found on the aluminum tag riveted to the back inside right corner of the toolbox on the driver's side.

Jerr-Dan Corporation strives to provide information that is accurate, complete and useful. All information contained in this manual is as accurate as known at the time of publication and is subject to change, without notice, as a result of continuous product improvements. Jerr-Dan reserves the right to amend the information in this document at any time without prior notice. Should you find inadequacies in the text, please send your comments to the following address:

Jerr-Dan Corporation
Attn: Technical Publications
1080 Hykes Road
Greencastle, PA 17225

or by e-mail at technicalpublications@jerr-dan.com.

Always keep this manual in the vehicle so the operator can study it as needed before a recovery. Remember to replace the manual if lost.

Additional or replacement manuals or replacement safety warning labels can be ordered by calling Jerr-Dan Parts at 717-597-7111. Price and availability will be quoted at time of the request.

The material in this document is the property of Jerr-Dan Corporation. No part of this document may be photocopied, reproduced or translated to another language without the express written consent of Jerr-Dan Corporation.

Manufactured under one or more of the following patents: 5,575,606; 5,722,810; 5,782,596; 5,839,775; 6,120,235; 6,290,450 B1 and 6,315,515 B1; 6,527,495 B1 with other Patents Pending.

Jerr-Dan and the Jerr-Dan logo are registered trademarks of Jerr-Dan Corporation, Greencastle, PA USA.

OPERATION

The Underlift Level Stop Assist System is a system that provides an interrupt to the remote control signal to stop the underlift travel at a desired loading position.

For proper operation of the Underlift Level Stop Assist system, follow these steps:

1. From the stored position, unfold the underlift boom using the **TILT DOWN** control function. The underlift boom will stop automatically at the factory set position.
2. Next, lower the underlift boom using the **UNDERLIFT DOWN** control function. The underlift boom will stop automatically at the factory set position just above the ground.

NOTE:

To override either stop position, simply release the control function and reactivate the same control function again to achieve further travel of the underlift.

MAINTENANCE

To change or adjust the factory set positions of the Underlift Level Stop Assist system, follow these steps:

MPL

1. To change the tilt stop, move the sensor on the underlift boom base up, to lower the boom, and down to raise the boom as shown below.

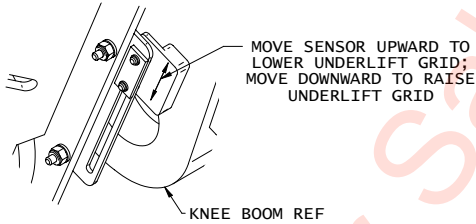

NOTE:

A GAP OF .125-.1875 MUST BE MAINTAINED BETWEEN THE SENSOR AND THE BASE BOOM SIDE PLATE. INTERMITTENT OPERATION WILL OCCUR IF THE GAP IS NOT MAINTAINED.

2. To change the boom stop, move the sensor on the boom lift cylinder up, to raise the boom, and down to lower the boom as shown below.

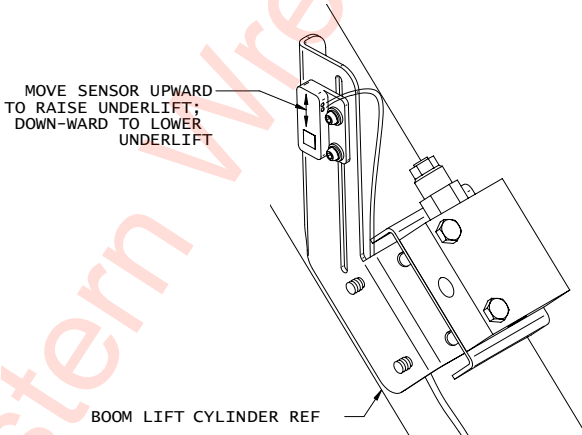

NOTE:

A GAP OF .125-.1875 MUST BE MAINTAINED BETWEEN THE SENSOR AND THE DOUBLER PLATE. INTERMITTENT OPERATION WILL OCCUR IF THE GAP IS NOT MAINTAINED.

MPL40

1. To change the tilt stop, move the sensor on the underlift boom base up, to lower the boom, and down to raise the boom as shown below.

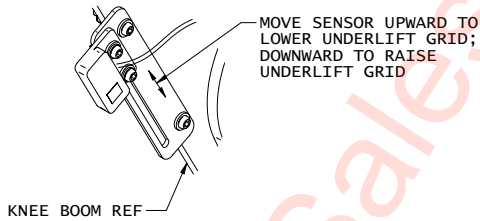

NOTE:

A GAP OF .125-.1875 MUST BE MAINTAINED BETWEEN THE SENSOR AND THE BASE BOOM SIDE PLATE. INTERMITTENT OPERATION WILL OCCUR IF THE GAP IS NOT MAINTAINED.

2. To change the boom stop, move the sensor on the boom lift cylinder up, to raise the boom, and down to lower the boom as shown below.

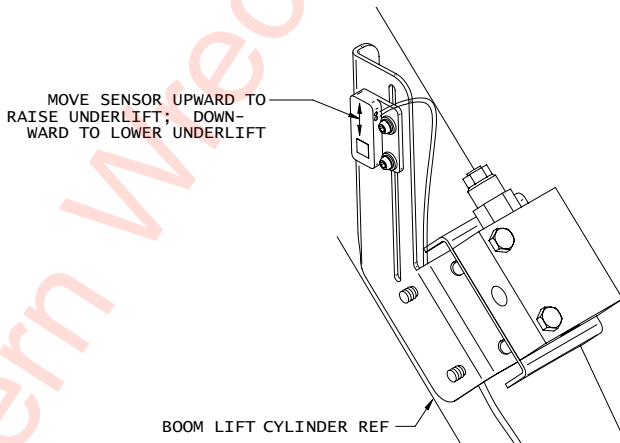

NOTE:

A GAP OF .125-.1875 MUST BE MAINTAINED BETWEEN THE SENSOR AND THE DOUBLER PLATE. INTERMITTENT OPERATION WILL OCCUR IF THE GAP IS NOT MAINTAINED.

JERR-DAN[®]

An Oshkosh Corporation Company

Eastern Wrecker Sales Inc